

# 2026

TOOLING SYSTEM

株洲市格威硬质合金工具有限责任公司  
Zhuzhou Grewin Tungsten Carbide Tools Co.Ltd

✉ info@gwcarbide.com

☎ +0086-18673327292

🌐 <https://grewintools.com>

📍 No.102,202, Plant 14, Zhichuang Plaza, Jinma Road,  
Tianyuan, Zhuzhou City, Hunan, China

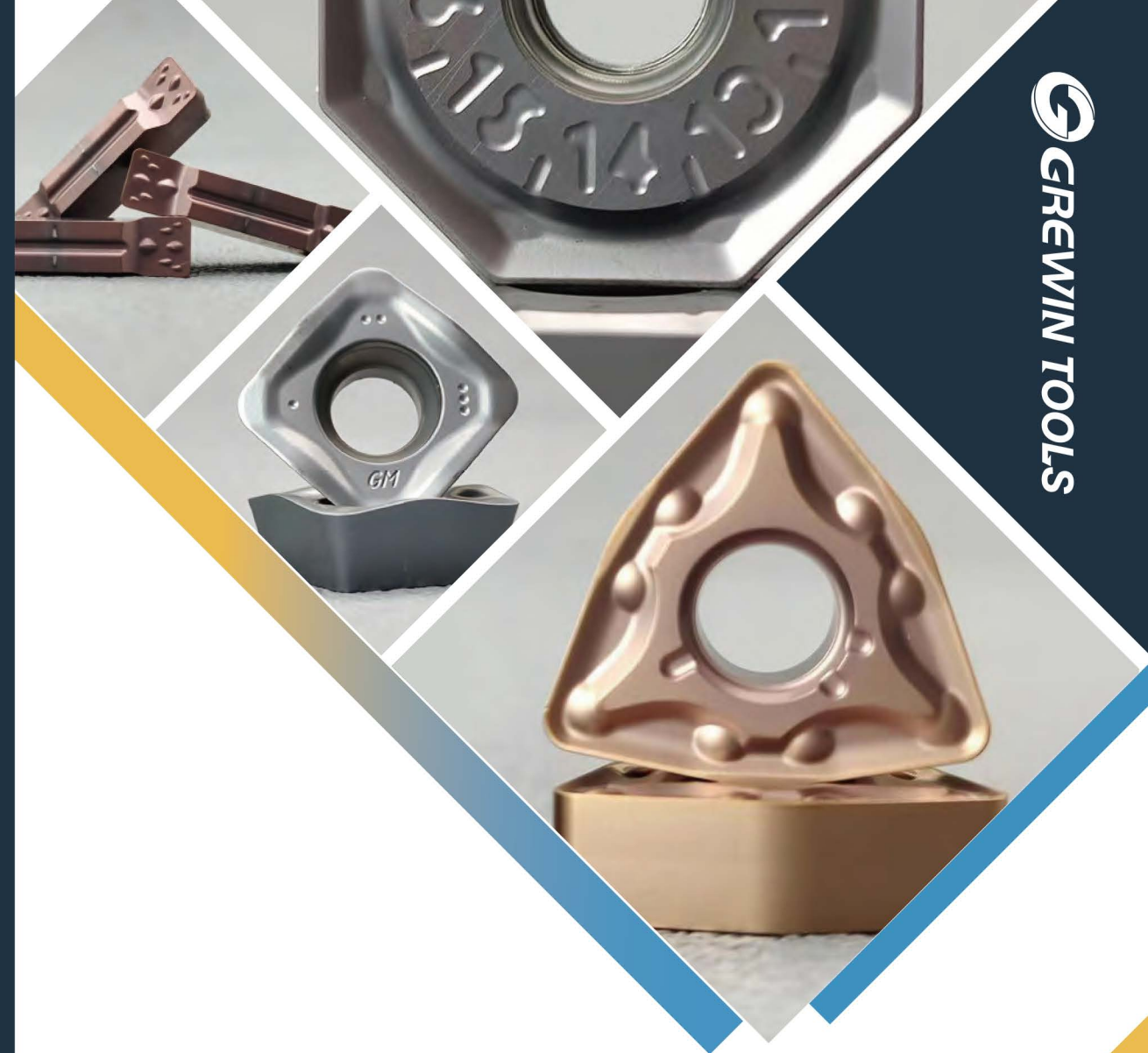

## CARBIDE INSERT

### 2026



# COMPANY PROFILE

Zhuzhou Grewin Tungsten Carbide Tools Co., Ltd is a rapid grow company expertise and professional in carbide materials and carbide cutting tools over 50 years of experience, integrated with new technology, high-end machinery and collaborate with cutting tool maker to make good quality tools for customers. Over the decade, we have actively collaborated with researcher and university to enhance the cutting tool design and tool life, we have successfully helped our customer to reduce their cost and gain more market share with us.

The company has a wide range of inspection equipment' s to fulfil products quality inspection, using ERP system for ordering processing, tracking and delivery.

The company mission and vision are to help customer solve the business needs by providing One-Stop Procurement peace of mind solution with various tungsten carbide material and carbide cutting tools for metalworking and woodworking to all customers all over the world.

our main products:

Metal cutting tools: carbide cutting insert, carbide end mill carbide drill carbide taps carbide reamers carbide saw blade

Wood working tool: wood cutting insert carbide drill bit saw blade and planer reversible cutting insert carbide saw tips

Solid carbide rod for metal & wood

Advertising working tools

Tungsten carbide preform tools like strips plate block

The company has ISO 9001:2008 quality system, possesses advanced production equipment' s, complete testing instruments, strong R&D center, and QC team. Grewin branding products are trusted brand sold to more than 80 countries in the world end to end, business to business such as USA, South America, Europe, Middle East, South East Asia, etc.

Grewin is dedicated – WE GROW TOGETHER WE WIN. Grewin is growing up with the worlds carbide technology to meet the demand of our customer from all over the world. The company even aggressively work with WWO and other organization on contributing back by carrying more socially responsible, reducing air pollution from our industry, blood donation and donation to the orphanage. To make social direct benefit.



## HIGH QUALITY ASSURANCE

Grewin Owns a complete CNC insert production line, it including raw materials spraying treatment, mold making, deep processing, coating, etc. we are committed to research and development on Solutions of high-performance CNC cutting tools.

We are Equipped with some worlds top brand of precision high-end equipment, such as OSTERWALDER multi-axis electric press, CNC peripheral grinder, Balzer coating furnace.

Grewin adopts automatic numerical control equipment for raw material preparation, pressing, sintering, coating and products inspection.

We also have the advanced equipment' s like Mikron machining center and leading coating processing and world-class quality control system to ensure the good quality of our carbide insert.

We are aiming to provide the high-quality CNC cutting tools and improve the production efficiency to users and fully meet the strict requirements on insert quality.





# Contents

**A** Turning Inserts .....A01~A128

**B** Milling Inserts .....B01~B48

**C** Drilling Inserts .....C02~C05

**D** Technical Information .....D01~D15





### Case No.1

Workpiece: Aircraft Components  
 Workpiece material: Inconel 718  
 Processing equipment: vertical lathe  
 Grewin insert: CNMG120408-DM GWR5101  
 Comparison insert: CNMG120408, a foreign brand  
 Comparison insert: CNMG120408, b foreign brand  
 Processing: Turning  
 Cutting parameters: Vc: 55m/min  
                                   f: 0.23mm/rev  
                                   ap: 0.5mm

Conclusion: Our insert takes 26 minutes to process, while the two competitors take 15 minutes to process. From the perspective of insert wear, WeCan's insert wear is relatively small, and the cost-effectiveness is extremely high.

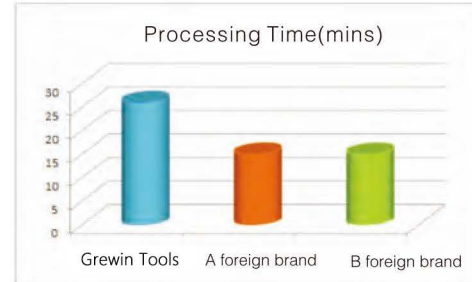

### Case No.2

Workpiece: Aircraft Components  
 Workpiece material: Inconel 718  
 Processing equipment: horizontal lathe  
 Grewin insert: CNMG120408-DM GWR5101  
 Comparison insert: CNMG120408, a foreign brand  
 Comparison insert: CNMG120408, b foreign brand  
 Processing: Turning  
 Cutting parameters: Vc: 55m/min  
                                   f: 0.28mm/rev  
                                   ap: 3.8mm

Conclusion: Our insert processing takes 8 minutes, while our two competitors process for 4 and 5 minutes respectively. Our insert life is better than our competitors, and the cost-effectiveness is higher.

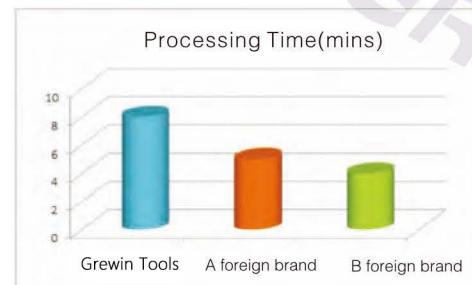

### Case No.3

Workpiece material: cast steel Inconel 718  
 Workpiece: Top Wire  
 Cooling type: Fluid cooling  
 Comparison insert: a foreign brand  
 Grewin Insert: WNMG080408-DMGWR5251  
 Cutting parameters: Vc: 40m/min, ap: 2mm, f: 0.21mm/rev  
 Conclusion: Our insert cutting is light and fast, with good chip breaking and low cutting resistance, which is comparable to the lifespan of a foreign brand. However, our insert has a high cost performance ratio.

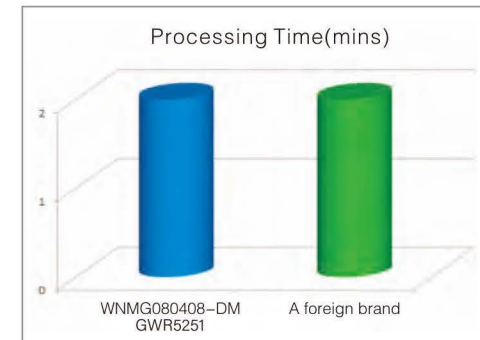

## Heat Resistant Alloys / Titanium Alloys Finishing Series



### GW6051

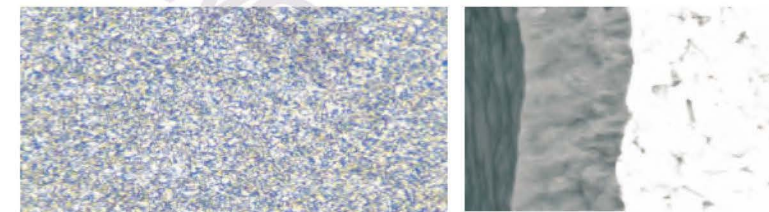

- ★ ISO:S05-S15 H05-H15 N05-N15
- ★ Low cobalt, ultra-fine grain hard alloy matrix, excellent wear resistance and heat resistance;
- ★ Paired with PVD High Power Impulse Magnetron Sputtering (HIPIMS) nano composite coating, the strongest coating adhesion and smooth surface;
  1. High hardness turning grade for small parts;
  2. Suitable for turning of P, M, and S type materials;
  3. Longer processing life and higher surface smoothness.



### Chip Breaker Features of -FL

- Precision grinding of the periphery, with high indexing accuracy.
- The large rake angle design makes a very sharp edge structure.
- The sharp cutting edge design ensures low cutting force and wide edge band further ensuring the sharpness of the cutting edge and ensuring good chip breaking.
- Surface polishing treatment and smooth chip discharge lead to excellent surface processing quality.

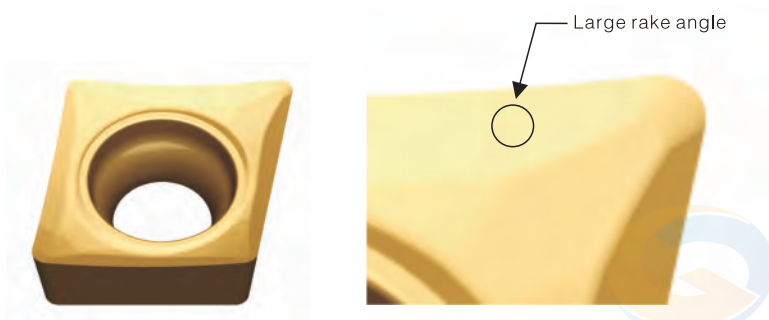

### Case No.1

Workpiece: Aircraft Components  
 Workpiece material: GH4169  
 Processing equipment: horizontal lathe  
 Grewin insert: CCGT09T302-FL GW6051  
 Comparison insert: CCGT09T302 a foreign brand  
 Processing: Turning  
 Cutting parameters:  $V_c$ : 40m/min  $f$ : 0.15mm/rev  $a_p$ : 0.1mm  
 Conclusion: Under the same parameter conditions, after processing for 1 hour, the wear of our insert and the safety insert are relatively similar, with a similar lifespan. Our insert has a high cost performance ratio.

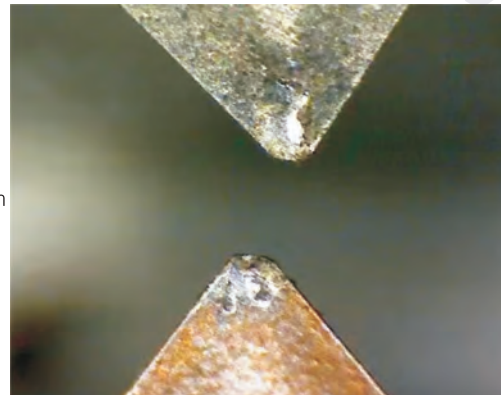

## Processing Sword for Stainless Steel

### 1 Chip Breaker Features of Stainless Steel Finishing -BF

- Double large positive rake angle, fully ensure the sharpness of the edge
- Small protrusions are more conducive to chip breaks
- Large cutting edge inclination can guide the chip flow very well
- Low cutting resistance, high surface finish of machined parts

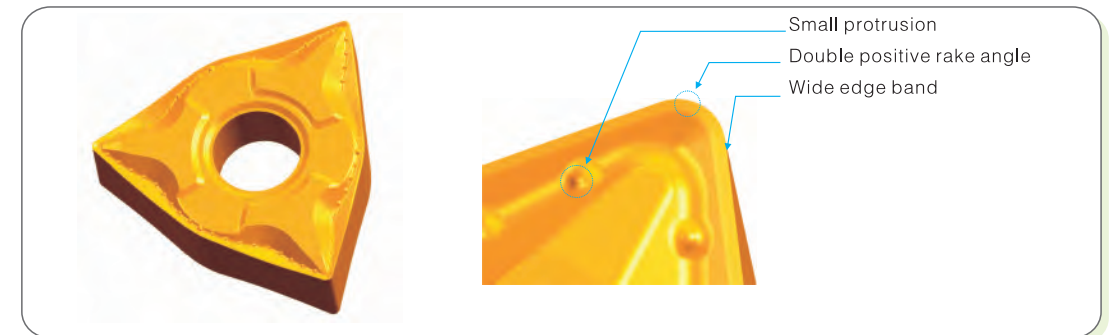

### 2 Chip Breaker Features of Stainless Steel Semi-Finishing -BM

- The combination of variable blade width and variable rake angle takes into account the sharpness and strength of the cutting edge.
- Plum-shaped chip breaker structure, widen the chip breaking range of the insert
- Suitable for semi-finishing of stainless steel.

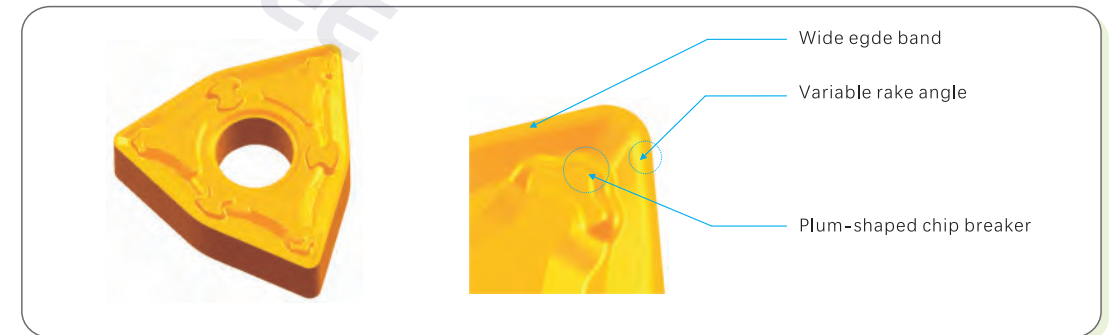



### 3 Chip Breaker Features of Stainless Steel Finishing -BR

- Variable blade width and variable rake angle design, taking into account the sharpness and strength of the blade
- Large chip breaker and chip pocket design provides excellent chip breaking effect.
- Double chip breaker design expands the backbreaking range.
- Suitable for semi-finishing to rough machining of stainless steel

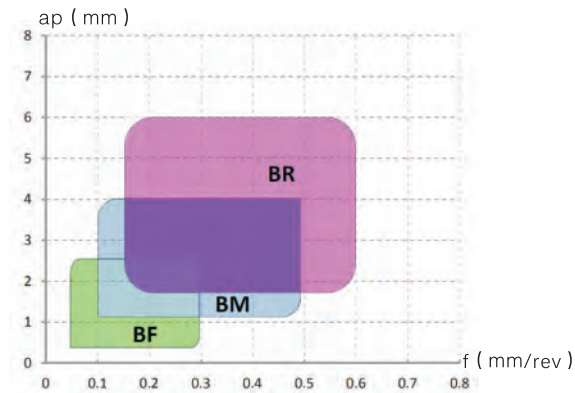
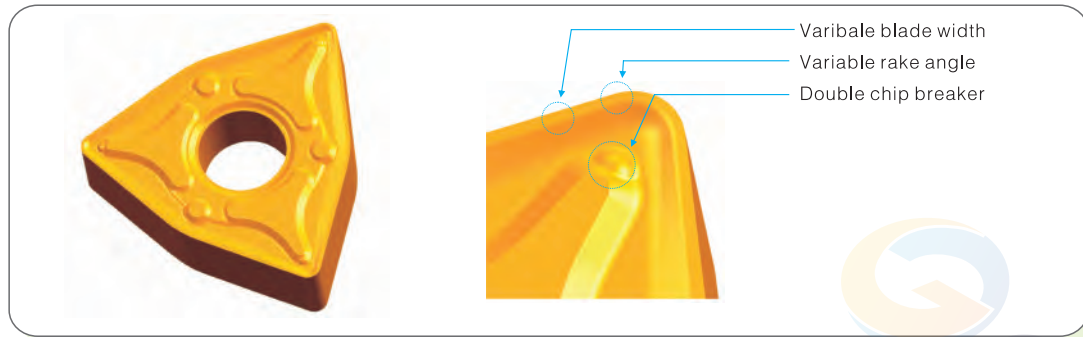

### Case No.1

Workpiece material:stainless steel SUS304  
 Workpiece: Flange  
 Cooling type:Fluid cooling  
 Original blade:A foreign brand  
 Grewin insert:WNMG080408-BR GW8281  
 Cutting parameter:Vc:153m/min, f:0.2mm/rev , ap:1 -2mm  
 Conclusion: Used for boring, uneven cutting allowance, our inserts processed 48 pieces, a foreign brand processed 41 pieces, tool life increased by 17%, and has the advantage of cost performance.

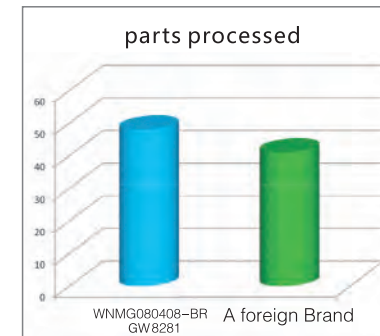

### Case No.2

Workpiece material:stainless steel SUS304  
 Workpiece:Flange  
 Cooling type:Fluid cooling  
 Original blade:A foreign brand  
 Grewin insert:WNMG080408-BR GW8281  
 Cutting parameter:Vc:170m/min , f:0.2mm/rev, ap:1-1.5mm  
 Conclusion: Processing stainless steel flange end face, our inserts processed 69 pieces, a foreign brand processed 56 pieces, tool life increased by 23%, the advantage is obvious and the customer is very satisfied.

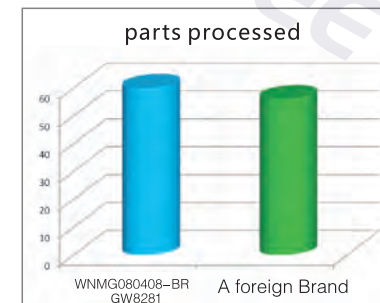



### Case No.3

Workpiece material:stainless steel SUS304  
 Workpiece: Flange  
 Cooling type:Fluid cooling  
 Original blade:A foreign brand  
 Grewin insert:WNMG080408-BM GW 8251  
 Cutting parameter: $V_c$ :220m/min  $f$ :0.2-0.3mm/rev  $a_p$ :0.8-1.5mm  
 Conclusion: processing flange outer circle, our inserts processed 16 pieces, a foreign brand processed 14 pieces, tool life increased by 14%, and our inserts processing work piece surface finish better than competitors.

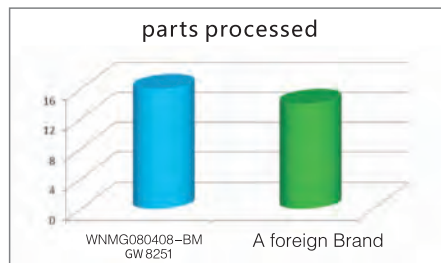

### Case No.4

Workpiece material:stainless steel SUS304  
 Workpiece:pipe joint  
 Cooling type:Fluid cooling  
 Original blade:A foreign brand  
 Grewin insert:TNMG160404-BF GW8281  
 Cutting parameter: $V_c$ :47m/min  $f$ :0.1mm/rev  $a_p$ :1mm  
 Conclusion: Machining the outer circle of pipe joint, our inserts processed 68 pieces, a foreign brand processed 49 pieces, the tool life increased by 39%, the cost performance advantage is obvious.

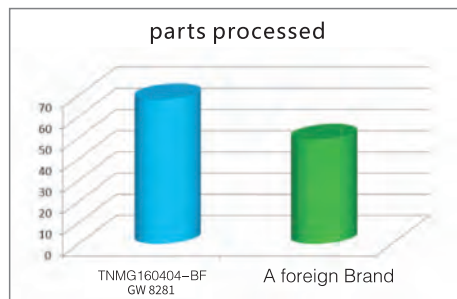

## GW2134/GW2234

# NEW

### Upgraded Material for Steel Processing

## $V_c$ up to 300m/min



TiN

Wear status recognition layer, yellow coating makes it easier to observe the wear of the front and rear cutting surfaces of the insert.

$Al_2O_3$

Excellent heat insulation and high temperature resistance layer, especially suitable for high-speed processing.

Ti(C,N)

Stronger wear resistance and high-temperature stability can significantly improve tool life.

Matrix

The matrix is designed specifically for steel processing, reduced the defects in alloys and improves the toughness of inserts.

### GW2134

- ★Medium temperature CVD coating, used for finishing to semi-finishing turning of steel, continuous and light intermittent processing;
- ★Optimization of matrix composition to enhance plastic deformation resistance and blade safety;
- ★Excellent wear resistance enables long service life processing at high speed under good working conditions.

### GW2234

- ★Medium temperature CVD coating, preferred grade for steel turning, used for semi-finishing to roughing;
- ★Improve the high-temperature strength and red hardness of the matrix, achieving excellent comprehensive performance;
- ★Stable processing under intermittent and harsh working conditions.



## The Features of CVD Coating

ISO	Grade	Colour	Coating Structure	Electron Microscopy Images	Features.Application
K Cast Iron	GW0203	Black	TiCN+Al <sub>2</sub> O <sub>3</sub>		High hardness matrix, thinned CVD coating, excellent wear resistance. Milling gray cast iron and ductile iron under stable working conditions.
	GW0403	Black	TiCN+Al <sub>2</sub> O <sub>3</sub>		High toughness matrix, thinned CVD coating, excellent resistance to chipping. Rough milling of cast iron, especially in harsh working conditions.
	GW1153	Black	TiCN+Al <sub>2</sub> O <sub>3</sub>		Optimized and extremely wear-resistant material, nano thick film CVD coating. Continuous or light intermittent turning of gray cast iron and ductile iron.
P Steel	GW2154	Yellow Black	TiCN+Al <sub>2</sub> O <sub>3</sub> + (TiN)		Wear-resistant substrate with resistance to plastic deformation, strong and tough coating with excellent bonding force. High-speed, high-efficiency turning of finishing-roughing steel.
	GW2254	Yellow Black	TiCN+Al <sub>2</sub> O <sub>3</sub> + (TiN)		A matrix with both wear resistance and chipping resistance, and a tough coating with excellent adhesion. The first choice for Intermittent - general turning of steel.
	GW2354	Yellow Black	TiCN+Al <sub>2</sub> O <sub>3</sub> + (TiN)		High toughness matrix, strong and tough coating with excellent bonding force, extremely high processing safety. Heavy-duty machining of steel and interrupted turning.
	<b>NEW</b> GW2134	Yellow Black	TiCN+Al <sub>2</sub> O <sub>3</sub> +TiN		High toughness matrix, strong and tough coating with excellent bonding strength, and extremely high processing safety. Heavy load machining and intermittent turning of steel parts.
	<b>NEW</b> GW2234	Yellow Black	TiCN+Al <sub>2</sub> O <sub>3</sub> +TiN		Upgraded product performance, with a matrix that combines wear resistance and blade collapse resistance, and a strong and tough coating with excellent bonding strength, the resistance to plastic deformation and crescent pit wear is improved. Longer lifespan for intermittent-general turning steel parts, also for heavy-duty machining.



## The Features of PVD Coating





ISO	Grade	Colour	Coating Structure	Electron Microscopy Images	Features.Application
P Steel	GW0151	Black	AlTiN		Submicron matrix resistant to abrasive wear and a coating with higher aluminum content. Stable milling of cast iron and steel parts.
	GW0251	Black	AlTiN		The Matrix balances hardness and toughness, and the coating with higher aluminum content. Suitable for general milling of cast iron, steel, and stainless steel, with high processing safety.
	GW8251	Bronze	AlTiMeN		Ultra fine grain matrix, newly upgraded nano composite coating with high heat resistance and high toughness. Suitable for general milling of cast iron, steel, and stainless steel, with superior wear resistance. Additional grade for stainless steel turning.
M Stainless Steel	GW8201	Bronze	AlTiMeN		Medium cobalt and ultra fine grain hard alloy matrix. High hardness nano composite PVD coating. The perfect fusion of high-strength, high toughness matrix and wear-resistant surface coating, comprehensive excellent performance.
	GW8241	Bronze	AlTiMeN		Special ultra-fine grain matrix with enhanced toughness and red hardness, and the latest high wear-resistant coating. General high-performance machining for efficient milling of steel, stainless steel, and heat-resistant alloys, as well as for stainless steel turning.
	GW5251	Purple Black	AlTiMeN		Nano multilayer coating with ultra-fine grain matrix, good wear resistance and oxidation resistance. Stable and long-life milling of steel and stainless steel.
	GW8281	Bronze	AlTiMeN		Submicron matrix, newly upgraded nano composite coating with high heat resistance and toughness. Preferred grade for stainless steel turning, supplementary machining of softer steel.
S Heat Resistant Alloy	GW6051	Bronze	AlTiSiN		Low cobalt, fine-grained wear-resistant and heat-resistant matrix. High hardness coatings deposited by high-energy pulse magnetron sputtering, with higher coating adhesion and has good wear resistance and heat resistance. Suitable for high-temperature alloy and titanium alloy turning, continuous and stable working conditions processing;
	GWR6101	Bronze	AlTiSiN		Superfine grain matrix reinforced with adhesive phase, excellent heat resistance and wear resistance. The high hardness coating deposited by HIPIMS has higher coating adhesion and good wear resistance and heat resistance. Suitable for finishing – semi-finishing turning of heat-resistant alloys and high hardness materials, and general milling.
	GWR5251	Purple Black	AlTiMeN		Superfine grain matrix optimized for heat resistance and toughness of heat-resistant alloys, with wear resistance and oxidation resistance. Good nano multilayer coating. The preferred grade for general machining of heat-resistant alloys.
	GWR0291	Black	AlTiN		Specially reinforced super tough matrix, high aluminum coating, higher cost-effectiveness. Efficient rough milling for steam turbine blades, long-life dry cutting, and also suitable for heat resistance Alloy.



## Recommended Turning Insert Grade





ISO	CVD				PVD			
	01	10	20	30	01	10	20	30
<b>K</b> Cast Iron	01							
	10		GW1153					
	20							
	30							
	40							
<b>P</b> Steel	01	GW2154		GW2134				
	10							
	20	GW2254			GW2234			
	30		GW2354					
	40							
<b>M</b> Stainless Steel	01				GW8201			
	10					GW8241	GW5251	GW8281
	20							
	30							
	40							
<b>S</b> Heat Resistant Alloy	01				GW6051	GW6101	GW1824	GW5251
	10							
	20							
	30							
	40							

## General Turning Insert



Item No.	Application	Chipbreaker	Feature/Shape of Insert
1	Steel Finishing	AF	P-type Material Finishing
			M-level double-sided chipbreaker, two-stage bump effect for stable chip handling in a wide range of feeds.
2	Steel Semi-finishing	AS	P-type Material Semi-finishing
			M-level double-sided chipbreaker, negative chamfer design, high edge strength, suitable for semi-finishing occasions with unstable working conditions.
3	Steel Medium machining	AM	P-type Material Medium machining
			Low cutting resistance due to double-angle cutting edge design, variable width design for sharpness and strength.
4	Steel Roughing	AG	P-type Material Roughing
			The preferred chip breaker for lightload roughing, wide margin design, good edge strength, high metal removal rate, good wear resistance and cutting life.
5	Steel Heavy-duty	AG (Single Side)	P-type Material Heavy-duty
			M-level single-sided chipbreaker, negative chamfer design, under the large cutting depth and large feed processing parameters, high edge strength and high metal removal rate can be obtained.





## General Turning Insert

Item No.	Application	Chipbreaker	Feature/Shape of Insert
6	Stainless steel finishing	BF	M type material finishing
			M-level double-sided chipbreaker, small edge width + double positive rake angle, sharp blade edge, low cutting resistance, special edge inclination design, can obtain high-quality machined surface.
7	Stainless steel semi-finishing	BM	M type material semi-finishing
			M-level double-sided chipbreaker, double positive rake angle, higher edge strength, widely application for the general processing of stainless steel.
8	Stainless steel roughing	BR	M type material roughing
			M-level double-sided chipbreaker, variable blade width and variable rake angle design, suitable for semi-finishing and roughing of stainless steel
9	High temperature alloy semi-finishing	DM	S type material semi-finishing
			M-level double-sided chipbreaker. Adopting the double positive rake angle combines the sharpness and strength of the insert; the cutting resistance is small, and the wider chipbreaker ensures enough space for chip deformation, reducing groove wear.

## General Inner Hole Turning Insert

Item No.	Application	Chipbreaker	Feature/Shape of Insert
10	General semi-finishing	GM	General chipbreaker
			M-level single-sided chipbreaker, suitable for semi-finishing of inner holes and outer circles of P, M and K type materials
11	Stainless steel finishing	GF	M type material finishing
			M-level single-sided chipbreaker, suitable for inner hole and outer circle finishing of stainless steel.

## Special Turning Insert

Item No.	Application	Chipbreaker	Feature/Shape of Insert
12	Train wheel hub machining	175.32 series	Chipbreaker for finishing of P type material
			M-level double-sided chipbreaker, vertical cutting inserts, especially suitable for the trimming of train wheels.
13	Train wheel hub machining	RCMX series	Chipbreaker for heavy-load machining of P type material
			M-level single-sided chipbreaker, negative chamfer design, high edge strength, first choice for profiling.



## Recommendation of Inserts and Chip Breakers

Finishing						
	CNMG-AF	DNMG-AF	SNMG-AF	TNMG-AF	VNMG-AF	WNMG-AF
Length	09/12	11/15	12	16/22	16	06/08
Page	A-27	A-37	A-46	A-56	A-65	A-69
Finishing						
	CNMG-BF	DNMG-BF	SNMG-BF	TNMG-BF	VNMG-BF	WNMG-BF
Length	09/12	15	12	16	16	06/08
Page	A-32	A-41	A-51	A-60	A-68	A-73
Semi-finishing						
	CNMG-AS	CNMG-AM	CNMG-BM	CNMG-CM	CNMG-DM	DNMG-AS
Length	12/16/19	12/16/19	12/16	12/16	12	15
Page	A-28	A-29	A-33	A-34	A-36	A-38
Semi-finishing						
	DNMG-AM	DNMG-BM	DNMG-CM	DNMG-DM	SNMG-AS	SNMG-AM
Length	15	15	15	15	12/15	12/15
Page	A-39	A-42	A-44	A-45	A-47	A-48
Semi-finishing						
	SNMG-BM	SNMG-CM	SNMG-DM	TNMG-AS	TNMG-AM	TNMG-BM
Length	12/15	12/16	12/15	16/22	16/22	16/22
Page	A-52	A-54	A-55	A-57	A-58	A-61

## Recommendation of Inserts and Chip Breakers

Semi-finishing						
	TNMG-CM	VNMG-AS	VNMG-AM	VNMG-CM	WNMG-AS	WNMG-AM
Length	16	11/16	11/16	16	08	08
Page	A-62	A-66	A-67	A-64	A-70	A-71
Semi-finishing						
	WNMG-BM	WNMG-CM	WNMG-DM			
Length	06/08	06/08	08			
Page	A-74	A-76	A-77			
Roughing						
	CNMG-AG	CNMG-BR	DNMG-AG	DNMG-BR	SNMG-AG	SNMG-BR
Length	12/16/19	12/16	15	15	12/15/19	12/15
Page	A-30	A-35	A-40	A-43	A-49	A-53
Roughing					Heavy-duty	
	TNMG-AG	TNMG-BR	WNMG-AG	WNMG-BR		CNMG-AG
Length	16/22	16/22	06/08	06/08	Length	19/25
Page	A-59	A-63	A-72	A-75	Page	A-31
Heavy-duty		Semi-finishing				
	SNMG-AG		CCMT-GM	DCMT-GM	SCMT-GM	TCMT-GM
Length	19/25	Length	06/09/12	07/11	09/12	09/11/16
Page	A-50	Page	A-78	A-80	A-82	A-84



## Recommendation of Inserts and Chip Breakers

M Finishing						
	CCMT-GF	DCMT-GF	SCMT-GF	TCMT-GF		
Length	06/09	07/11	09	09/11/16		
Page	A-79	A-81	A-83	A-85		
<b>NEW</b> Small Parts Machining						
	TNGG-FS	VNGG-FS	DCGT-FS	VBGT-FS	VCGT-FS	
Length	11	16	11	11	11	
Page	A-87	A-88	A-89	A-90	A-91	
GRINDED Small Parts Machining						
	CCGT-UF	DCGT-UF	TCGT-UF	VCGT-UF		
Length	09	07/11	11	08/11		
Page	A-92	A-93	A-97	A-95		
GRINDED Small Parts Machining						
	TNGG-F	TNGG-M	TPGH			
Length	16	16	08/09/11			
Page	A-96	A-97	A-98			
Semi-finishing						
	CCMT-DM	DCMT-DM	SCMT-DM	TCMT-DM		
Length	12	07/11	09	11		
Page	A-99	A-100	A-101	A-102		

Train Wheel Hub Machining						
	RCMX	175.32-22	175.32-24	175.32-28		
Length	08/32	19	19	19		
Page	A-103	A-104	A-105	A-106		

<b>NEW</b> Parting and Grooving						
	EDMN-C	EDMN-J	ECMN-T	ERMN-T	MGGN-GL	
Length	2.0-5.0	2.0-5.0	3.0-6.0	3.0-6.0	2.0-5.0	
Page	A-109	A-110	A-111	A-112	A-113	
<b>NEW</b> Parting and Grooving						
	ERMN-M					
Length	2.0-8.0					
Page	A-114					
GRINDED Grooving						
	TGF32R/L	GBA43R/L	TKF12R/L	TKF16R/L		
Length	1.1-3.0	1.25-3.0	0.5-2.0	1.5-2.0		
Page	A-116	A-117	A-118	A-119		



## Turning Insert Code Key

1. Shape			4. Chip Breaker and Hole							
			B	Y	N		N	N	N	
			H	Y	Single		R	N	Single	
			C	Y	N		F	N	Double	
			J	Y	Double		A	Y	N	
			W	Y	N		M	Y	Single	
		Others	T	Y	Single		G	Y	Double	
			Q	Y	N		X	---	---	Special Type
			U	Y	Double					
			Code	Center Hole	Chip Breaker	Insert Profile	Code	Center Hole	Chip Breaker	Insert Profile

Inscribed Circle diameter (mm)	Insert Shape						
	C	D	R	S	T	V	W
32.00							
31.75							
25.40							
25.00	25	25					
20.00							
19.05	19				19	33	
16.00		19			16		
15.875	16				15	15	27
12.70	12	15			12	22	22 08
12.00					12		
10.00					10		
9.525	09	11			09	16	16 06 16
8.00					08		
6.35	06	07				11	11
6.00					06		
5.56						09	
5.50					05		
3.97						06	

Code	Thickness (mm)
12	12.70
10	11.11
T9	9.72
09	9.52
07	7.94
T6	6.75
06	6.35
05	5.56
T4	4.96
04	4.76
T3	3.97
03	3.18
T2	2.78
02	2.38
T1	1.98
01	1.59
T0	0.99
00	0.79

C N M G

2. Clearance Angle				3. Tolerance										
Code	Clearance Angle	Code	Clearance Angle											
A	3°	B	5°	Code	m (mm)	d=I.C	S (mm)	• Tolerance of Inscribed Circle (mm)						
C	7°	D	15°	A	±0.005	±0.025	±0.025	Inscribed Circle	Regular Triangle	Square	80° Rhombus	55° Rhombus	35° Rhombus	
E	20°	F	25°	F	±0.005	±0.013	±0.025	6.35	±0.08	±0.08	±0.08	±0.11	±0.16	---
G	30°	N	0°	C	±0.013	±0.025	±0.025	9.525	±0.08	±0.08	±0.08	±0.11	±0.16	---
P	11°	O	Others	H	±0.013	±0.013	±0.025	12.7	±0.13	±0.13	±0.13	±0.15	---	---
				E	±0.025	±0.025	±0.025	15.875	±0.15	±0.15	±0.15	±0.18	---	---
				G	±0.025	±0.025	±0.13	19.05	±0.15	±0.15	±0.15	±0.18	---	---
				J	±0.005	±0.05±0.13	±0.025	25.4	---	±0.18	---	---	---	---
				K	±0.013	±0.05±0.13	±0.025	• Tolerance of Inscribed Circle (mm)						
				L	±0.025	±0.05±0.13	±0.025	Inscribed Circle	Regular Triangle	Square	80° Rhombus	55° Rhombus	35° Rhombus	
				M	±0.08±0.18	±0.05±0.13	±0.13	6.35	±0.05	±0.05	±0.05	±0.05	±0.05	---
				N	±0.08±0.18	±0.05±0.13	±0.025	9.525	±0.05	±0.05	±0.05	±0.05	±0.05	±0.05
				U	±0.13±0.38	±0.08±0.25	±0.13	12.7	±0.08	±0.08	±0.08	±0.08	---	±0.08
								15.875	±0.10	±0.10	±0.10	±0.10	---	±0.10
								19.05	±0.10	±0.10	±0.10	±0.10	---	±0.10
								25.4	---	±0.13	---	---	---	±0.13

12 04 12 - AS (ISO)

4 4 3 (Inch)

Code	Inscribed Circle diameter (mm)
2	6.35
3	9.525
4	12.7
5	15.875
6	19.05
8	25.4

Code	Thickness (mm)
2	3.18
3	4.76
4	6.35
5	7.94
6	9.52

Code	Corner Radius (mm)
0	0.2
1	0.4
2	0.8
3	1.2
4	1.6
5	2.0
6	2.4

Code	Corner Radius (mm)
00	
02	0.2
04	0.4
08	0.8
12	1.2
16	1.6
20	2.0
24	2.4
32	3.2
X	
Insert Diameter (Metric)	Circle Insert

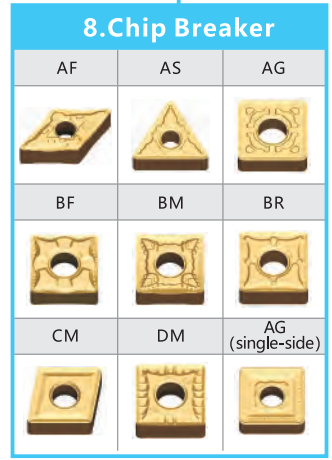



# Turning Inserts

GREWIN&COWEE  
CUTTING TOOLS

## Negative Inserts

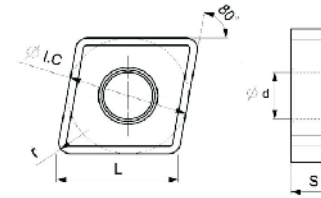

Length	Size(mm)			
	IC	S	d	r
9	9.525	3.18	3.81	0.4-0.8
12	12.7	4.76	5.16	0.4-1.2

## 80° CNMG With Hole

Shape	Type	ap (mm)	f (mm/rev)	Grade														
				CVD					PVD									
				GW0203	GW0403	GW1153	GW2134	GW2234	GW2354	GW0251	GW5251	GW8251	GW8241	GW8281	GWR6101	GWR5251		
	CNMG090304-AF	0.26-3.2	0.05-0.15				●	○										
	CNMG090308-AF	0.52-3.2	0.1-0.30				●	○										
	CNMG120404-AF	0.26-3.2	0.05-0.15				●	○										
	CNMG120408-AF	0.52-3.2	0.1-0.30				●	○										
	CNMG120412-AF	0.78-3.2	0.15-0.45				●	○										
P Finishing																		

Note: ●Recommended grade ready to stock

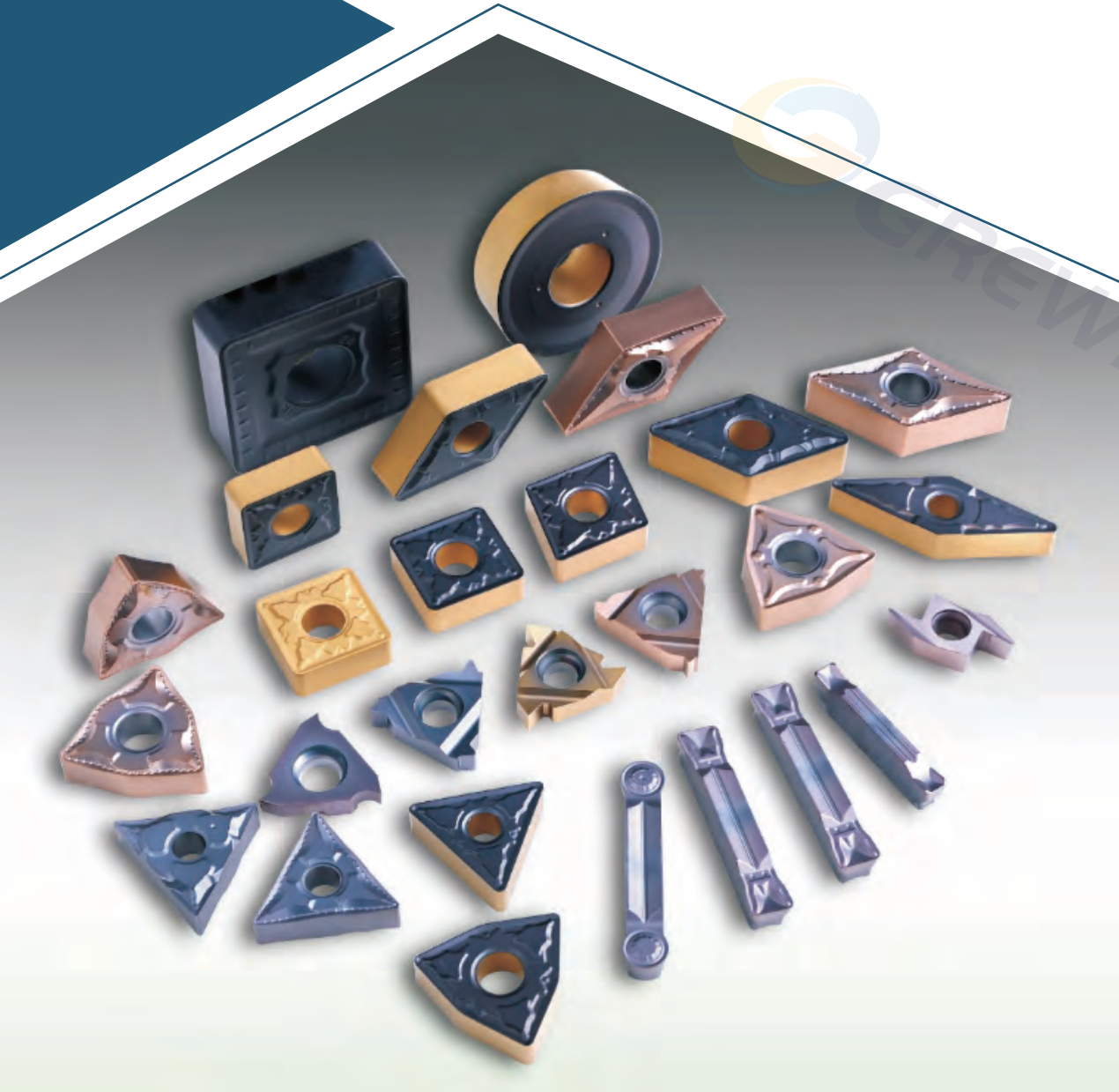



## Negative Inserts

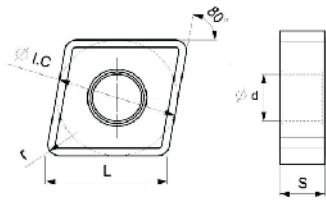

Length	Size(mm)			
	IC	S	d	r
12	12.7	4.76	5.16	0.4-1.6
16	15.875	6.35	6.35	0.8-1.6
19	19.05	6.35	7.94	0.8-1.6

### 80° CNMG With Hole

Shape	Type	ap (mm)	f (mm/rev)	Grade																		
				CVD						PVD												
				GW0203	GW0403	GW1153	GW2134	GW2234	GW2354	GW0251	GW5251	GW8251	GW8241	GW8281	GWR6101	GWR5251						
	CNMG120404-AS	0.60-6.40	0.10-0.30				○	●	○													
	CNMG120408-AS	1.20-6.40	0.20-0.60				○	●	○													
	CNMG120412-AS	1.80-6.40	0.30-0.90				○	●	○													
	CNMG120416-AS	2.40-6.40	0.12-0.40				○	●	○													
	CNMG160608-AS	1.20-8.10	0.10-0.30				○	●	○													
	CNMG160612-AS	1.80-8.10	0.20-0.60				○	●	○													
	CNMG160616-AS	2.40-8.10	0.30-0.90				○	●	○													
	CNMG190608-AS	1.20-9.70	0.20-0.60				○	●	○													
	CNMG190612-AS	1.80-9.70	0.30-0.90				○	●	○													
	CNMG190616-AS	2.40-9.70	0.40-1.20				○	●	○													

Note: ●Recommended grade ready to stock

## Negative Inserts

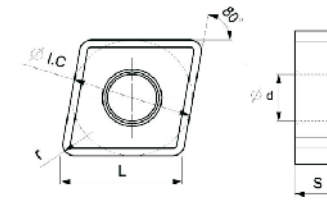

Length	Size(mm)			
	IC	S	d	r
12	12.7	4.76	5.16	0.4-1.6
16	15.875	6.35	6.35	0.8-1.6
19	19.05	6.35	7.94	0.8-1.6

### 80° CNMG With Hole

Shape	Type	ap (mm)	f (mm/rev)	Grade																		
				CVD						PVD												
				GW0203	GW0403	GW1153	GW2134	GW2234	GW2354	GW0251	GW5251	GW8251	GW8241	GW8281	GWR6101	GWR5251						
	CNMG120404-AM	0.4-5.5	0.10-0.30				○	●	○													
	CNMG120408-AM	0.5-5.5	0.15-0.50				○	●	○													
	CNMG120412-AM	0.8-5.5	0.18-0.60				○	●	○													
	CNMG120416-AM	1.0-5.5	0.23-0.65				○	●	○													
	CNMG160608-AM	0.5-7.2	0.15-0.50				○	●	○													
	CNMG160612-AM	0.8-7.2	0.18-0.60				○	●	○													
	CNMG160616-AM	1.0-7.2	0.23-0.65				○	●	○													
	CNMG190608-AM	0.5-8.6	0.15-0.50				○	●	○													
	CNMG190612-AM	0.8-8.6	0.16-0.60				○	●	○													
	CNMG190616-AM	0.8-8.6	0.16-0.60				○	●	○													

Note: ●Recommended grade ready to stock



## Negative Inserts

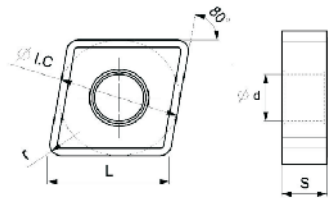

Length	Size(mm)			
	IC	S	d	r
12	12.7	4.76	5.16	0.8-1.6
16	15.875	6.35	6.35	0.8-1.6
19	19.05	6.35	7.94	0.8-2.4

### 80° CNMG With Hole

Shape	Type	ap (mm)	f (mm/rev)	Grade																		
				CVD						PVD												
				GW0203	GW0403	GW1153	GW2134	GW2234	GW2354	GW0251	GW5251	GW8251	GW8241	GW8281	GWR6101	GWR5251						
P Roughing	CNMG120408-AG	1.45-5.20	0.15-0.32				○	●	●													
	CNMG120412-AG	2.15-5.20	0.25-0.50				○	●	●													
	CNMG120416-AG	2.90-5.20	0.30-0.65				○	●	●													
	CNMG160608-AG	1.45-6.40	0.15-6.35				○	●	●													
	CNMG160612-AG	2.15-6.40	0.24-0.50				○	●	●													
	CNMG160616-AG	2.90-6.40	0.30-0.65				○	●	●													
	CNMG190608-AG	1.45-7.70	0.15-0.35				○	●	●													
	CNMG190612-AG	2.15-7.70	0.25-0.50				○	●	●													
	CNMG190616-AG	2.90-7.70	0.30-0.65				○	●	●													
	CNMG190624-AG	4.30-7.70	0.45-0.95				○	●	●													

Note: ●Recommended grade ready to stock

## Negative Inserts

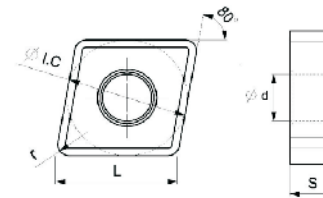

Length	Size(mm)			
	IC	S	d	r
19	19.05	6.35	7.94	1.2-2.4
25	25.4	7.94-9.52	9.12	2.4-3.2

### 80° CNMG With Hole

Shape	Type	ap (mm)	f (mm/rev)	Grade																		
				CVD						PVD												
				GW0203	GW0403	GW1153	GW2134	GW2234	GW2354	GW0251	GW5251	GW8251	GW8241	GW8281	GWR6101	GWR5251						
P Heavy -duty	CNMM190612-AG	2.40-9.70	0.25-0.60				○	●	●													
	CNMM190616-AG	3.20-9.70	0.35-0.80				○	●	●													
	CNMM190624-AG	4.80-9.70	0.50-1.20				○	●	●													
	CNMM250724-AG	4.80-12.90	0.50-1.20				○	●	●													
	CNMM250924-AG	4.80-12.90	0.50-1.20				○	●	●													
	CNMM250932-AG	4.80-12.90	0.50-1.20				○	●	●													

Note: ●Recommended grade ready to stock



## Negative Inserts

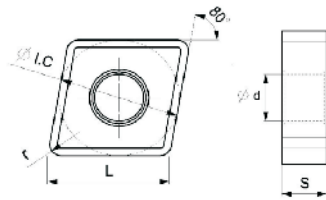

Length	Size(mm)			
	IC	S	d	r
9	9.525	3.18	3.81	0.4-0.8
12	12.7	4.76	5.16	0.4-1.2
16	15.875	6.35	6.35	0.8-1.6

### 80° CNMG With Hole

Shape	Type	ap (mm)	f (mm/rev)	Grade																				
				CVD						PVD														
				GW0203	GW0403	GW1153	GW2134	GW2234	GW2354	GW0251	GW5251	GW8251	GW8241	GW8281	GWR6101	GWR5251								
 M Finishing	CNMG090304-BF	0.25-2.40	0.05-0.15																					
	CNMG090308-BF	0.50-2.40	0.10-0.30																					
	CNMG120404-BF	0.25-3.20	0.05-0.15																					
	CNMG120408-BF	0.50-3.20	0.10-0.30																					
	CNMG120412-BF	0.75-3.20	0.15-0.45																					

Note: ● Recommended grade ready to stock

## Negative Inserts

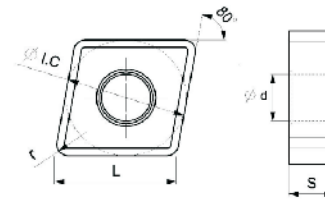

Length	Size(mm)			
	IC	S	d	r
12	12.7	4.76	5.16	0.4-1.2
16	15.875	6.35	6.35	0.8-1.6

### 80° CNMG With Hole

Shape	Type	ap (mm)	f (mm/rev)	Grade																				
				CVD						PVD														
				GW0203	GW0403	GW1153	GW2134	GW2234	GW2354	GW0251	GW5251	GW8251	GW8241	GW8281	GWR6101	GWR5251								
 M Semi-finishing	CNMG120404-BM	0.30-4.30	0.08-0.25																					
	CNMG120408-BM	0.65-4.30	0.15-0.45																					
	CNMG120412-BM	0.95-4.30	0.20-0.65																					
	CNMG160608-BM	0.65-5.30	0.15-0.45																					
	CNMG160612-BM	0.95-5.30	0.25-0.65																					
	CNMG160616-BM	1.30-5.30	0.30-0.90																					

Note: ● Recommended grade ready to stock



## Negative Inserts

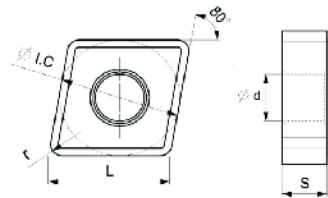

Length	Size(mm)			
	IC	S	d	r
12	12.7	4.76	5.16	0.4-1.6
16	15.875	6.35	6.35	0.8-1.6
19	19.05	6.35	7.94	0.8-1.6

80° CNMG With Hole

Shape	Type	ap (mm)	f (mm/rev)	Grade																			
				CVD						PVD													
				GW0203	GW0403	GW1153	GW2134	GW2234	GW2354	GW0251	GW5251	GW8251	GW8241	GW8281	GWR6101	GWR5251							
K Semi-finishing	CNMG120404-CM	0.40-4.30	0.08-0.25			●	○	○															
	CNMG120408-CM	0.80-4.30	0.15-0.45			●	○	○															
	CNMG120412-CM	1.20-4.30	0.20-0.65			●	○	○															
	CNMG160612-CM	1.20-5.30	0.25-0.65			●	○	○															
	CNMG160616-CM	1.60-5.30	0.30-0.90			●	○	○															
	CNMG190612-CM	1.20-6.40	0.25-0.65			●	○	○															

Note: ●Recommended grade ready to stock

## Negative Inserts

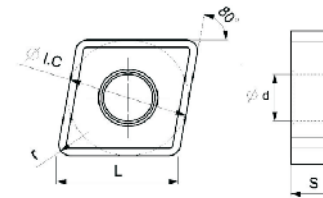

Length	Size(mm)			
	IC	S	d	r
12	12.7	4.76	5.16	0.4-1.2
16	15.875	6.35	6.35	0.8-1.6

80° CNMG With Hole

Shape	Type	ap (mm)	f (mm/rev)	Grade																			
				CVD						PVD													
				GW0203	GW0403	GW1153	GW2134	GW2234	GW2354	GW0251	GW5251	GW8251	GW8241	GW8281	GWR6101	GWR5251							
M Roughing	CNMG120404-BR	0.30-4.30	0.08-0.25																				
	CNMG120408-BR	0.65-4.30	0.15-0.45																				
	CNMG120412-BR	0.95-4.30	0.25-0.65																				
	CNMG160608-BR	0.65-5.30	0.15-0.45																				
	CNMG160612-BR	0.95-5.30	0.25-0.65																				
	CNMG160616-BR	1.25-5.30	0.30-0.90																				

Note: ●Recommended grade ready to stock





## Negative Inserts

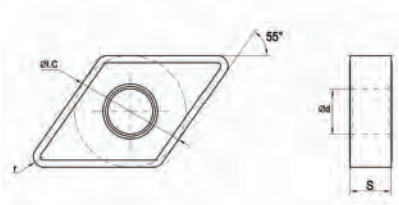

Length	Size(mm)			
	IC	S	d	r
15	12.7	4.76-6.35	5.16	0.4-1.2

55° DNMG With Hole

Shape	Type	ap (mm)	f (mm/rev)	Grade																			
				CVD						PVD													
				GW0203	GW0403	GW1153	GW2134	GW2234	GW2354	GW0251	GW5251	GW8251	GW8241	GW8281	GWR6101	GWR5251							
P Semi-finishing	DNMG150404-AS	0.60-5.40	0.10-0.30				○	●	○														
	DNMG150408-AS	1.20-5.40	0.20-0.60				○	●	○														
	DNMG150412-AS	1.80-5.40	0.30-0.90				○	●	○														
	DNMG150604-AS	0.60-5.40	0.10-0.30				○	●	○														
	DNMG150608-AS	1.20-5.40	0.20-0.60				○	●	○														
	DNMG150612-AS	1.80-5.40	0.30-0.90				○	●	○														

Note: ● Recommended grade ready to stock

## Negative Inserts

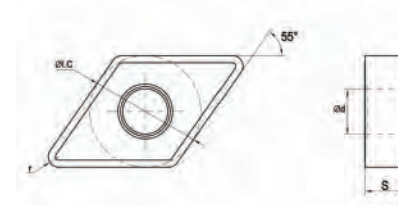

Length	Size(mm)			
	IC	S	d	r
15	12.7	4.76-6.35	5.16	0.4-1.2

55° DNMG With Hole

Shape	Type	ap (mm)	f (mm/rev)	Grade																			
				CVD						PVD													
				GW0203	GW0403	GW1153	GW2134	GW2234	GW2354	GW0251	GW5251	GW8251	GW8241	GW8281	GWR6101	GWR5251							
P Medium machining	DNMG150404-AM	0.4-6.0	0.10-0.3				○	●	○														
	DNMG150408-AM	0.5-6.0	0.15-0.5				○	●	○														
	DNMG150412-AM	0.8-6.0	0.18-0.6				○	●	○														
	DNMG150604-AM	0.4-6.0	0.10-0.3				○	●	○														
	DNMG150608-AM	0.5-6.0	0.15-0.5				○	●	○														
	DNMG150612-AM	0.8-6.0	0.18-0.6				○	●	○														

Note: ● Recommended grade ready to stock



## Negative Inserts

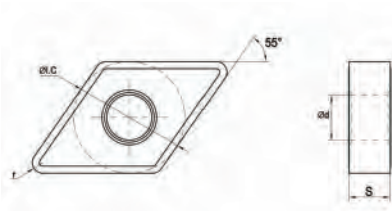

Length	Size(mm)			
	IC	S	d	r
15	12.7	4.76-6.35	5.16	0.8-1.2

55° DNMG With Hole

Shape	Type	ap (mm)	f (mm/rev)	Grade													
				CVD						PVD							
				GW0203	GW0403	GW1153	GW2134	GW2234	GW2354	GW0251	GW5251	GW8251	GW8241	GW8281	GWR6101	GWR5251	
P Roughing	DNMG150408-AG	0.80-4.0	0.15-0.50				○	●	●								
	DNMG150412-AG	1.20-4.0	0.15-0.65				○	●	●								
	DNMG150608-AG	0.80-4.0	0.15-0.50				○	●	●								
	DNMG150612-AG	1.20-4.0	0.15-0.65				○	●	●								

Note: ●Recommended grade ready to stock

## Negative Inserts

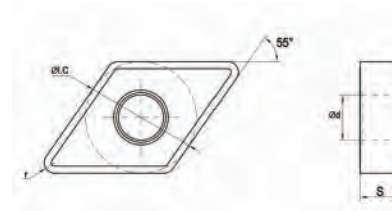

Length	Size(mm)			
	IC	S	d	r
15	12.7	4.76-6.35	5.16	0.4-1.2

55° DNMG With Hole

Shape	Type	ap (mm)	f (mm/rev)	Grade																		
				CVD						PVD												
				GW0203	GW0403	GW1153	GW2134	GW2234	GW2354	GW0251	GW5251	GW8251	GW8241	GW8281	GWR6101	GWR5251						
M Finishing	DNMG150404-BF	0.25-2.90	0.05-0.15													○	●	○	●			
	DNMG150408-BF	0.50-2.90	0.10-0.30													○	●	○	●			
	DNMG150412-BF	0.75-2.90	0.15-0.45													○	●	○	●			
	DNMG150604-BF	0.25-2.90	0.05-0.15													○	●	○	●			
	DNMG150608-BF	0.50-2.90	0.10-0.30													○	●	○	●			
	DNMG150612-BF	0.75-2.90	0.15-0.45													○	●	○	●			

Note: ●Recommended grade ready to stock





## Negative Inserts

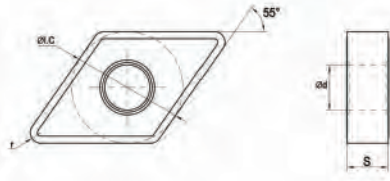

Length	Size(mm)			
	IC	S	d	r
15	12.7	6.35	5.16	0.8-1.2

55° DNMG With Hole

Shape	Type	ap (mm)	f (mm/rev)	Grade																				
				CVD						PVD														
				GW0203	GW0403	GW1153	GW2134	GW2234	GW2354	GW0251	GW5251	GW8251	GW8241	GW8281	GWR6101	GWR5251								
	DNMG150404-CM	0.40-3.90	0.08-0.25			●	○	○																
	DNMG150408-CM	0.80-3.90	0.15-0.45			●	○	○																
	DNMG150412-CM	1.20-3.90	0.25-0.65			●	○	○																
	DNMG150604-CM	0.40-3.90	0.08-0.20			●	○	○																
	DNMG150608-CM	0.80-3.90	0.15-0.45			●	○	○																
	DNMG150612-CM	1.20-3.90	0.25-0.65			●	○	○																
K Semi-finishing																								

Note: ●Recommended grade ready to stock

## Negative Inserts

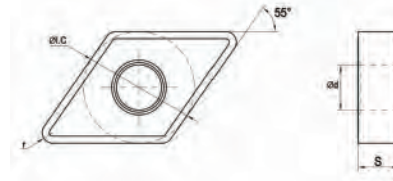

Length	Size(mm)			
	IC	S	d	r
15	12.7	4.76-6.35	5.16	0.4-1.2

55° DNMG With Hole

Shape	Type	ap (mm)	f (mm/rev)	Grade																				
				CVD				PVD																
				GW1153	GW2134	GW2234	GW2354	GW0251	GW5251	GW8251	GW8241	GW8281	GW6051	GW5101	GWR6101	GWR5251								
	DNMG150404-DM	0.40-3.90	0.08-0.25												○						●	○	●	
	DNMG150408-DM	0.80-3.90	0.15-0.45												○							●	○	●
	DNMG150412-DM	1.20-3.90	0.25-0.65												○							●	○	●
	DNMG150604-DM	0.40-3.90	0.08-0.20												○							●	○	●
	DNMG150608-DM	0.80-3.90	0.15-0.45												○							●	○	●
	DNMG150612-DM	1.20-3.90	0.25-0.65												○							●	○	●
S Semi-finishing																								

Note: ●Recommended grade ready to stock



## Negative Inserts

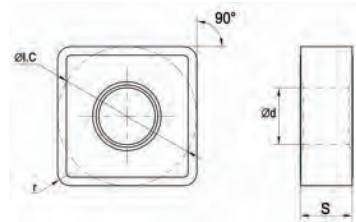

Length	Size(mm)			
	IC	S	d	r
12	12.7	4.76	5.16	0.8-1.2

90° SNMG With Hole

Shape	Type	ap (mm)	f (mm/rev)	Grade														
				CVD							PVD							
				GW0203	GW0403	GW1153	GW2134	GW2234	GW2354	GW0251	GW5251	GW8251	GW8241	GW8281	GWR6101	GWR5251		
P Finishing	SNMG120404-AF	0.26-3.2	0.05-0.15				●	○										
	SNMG120408-AF	0.52-3.2	0.10-0.30				●	○										
	SNMG120412-AF	0.78-3.2	0.15-0.45				●	○										

Note: ●Recommended grade ready to stock

## Negative Inserts

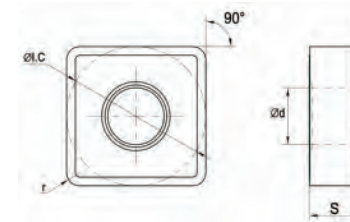

Length	Size(mm)			
	IC	S	d	r
12	12.7	4.76	5.16	0.8-1.6
15	15.875	6.35	6.35	0.8-1.2

90° SNMG With Hole

Shape	Type	ap (mm)	f (mm/rev)	Grade														
				CVD							PVD							
				GW0203	GW0403	GW1153	GW2134	GW2234	GW2354	GW0251	GW5251	GW8251	GW8241	GW8281	GWR6101	GWR5251		
P Semi-finishing	SNMG120404-AS	1.00-5.00	0.12-0.40				○	●	○									
	SNMG120408-AS	1.20-5.00	0.15-0.55				○	●	○									
	SNMG120412-AS	1.50-5.00	0.20-0.55				○	●	○									
	SNMG150612-AS	2.00-7.00	0.30-0.65				○	●	○									

Note: ●Recommended grade ready to stock



## Negative Inserts

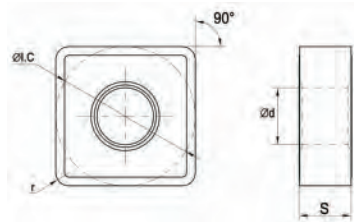

Length	Size(mm)			
	IC	S	d	r
12	12.7	4.76	5.16	0.8-1.6
15	15.875	6.35	6.35	0.8-1.2

90° SNMG With Hole

Shape	Type	ap (mm)	f (mm/rev)	Grade																				
				CVD						PVD														
				GW0203	GW0403	GW1153	GW2134	GW2234	GW2354	GW0251	GW5251	GW8251	GW8241	GW8281	GWR6101	GWR5251								
 P Medium machining	SNMG120404-AM	0.4-6.0	0.10-0.3				○	●	○															
	SNMG120408-AM	0.5-6.0	0.15-0.5				○	●	○															
	SNMG120412-AM	0.8-6.0	0.18-0.6				○	●	○															
	SNMG150612-AM	0.8-7.5	0.18-0.6				○	●	○															

Note: ●Recommended grade ready to stock

## Negative Inserts

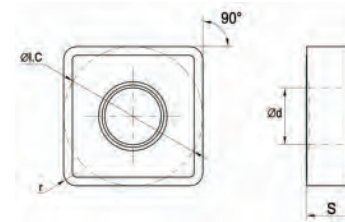

Length	Size(mm)			
	IC	S	d	r
12	12.7	4.76	5.16	0.8-1.6
15	15.875	6.35	6.35	0.8-1.2
19	19.05	6.35	7.94	1.2-1.6

90° SNMG With Hole

Shape	Type	ap (mm)	f (mm/rev)	Grade																				
				CVD						PVD														
				GW0203	GW0403	GW1153	GW2134	GW2234	GW2354	GW0251	GW5251	GW8251	GW8241	GW8281	GWR6101	GWR5251								
 P Roughing	SNMG120408-AG	2.50-6.00	0.25-0.70				○	●	●															
	SNMG120412-AG	2.50-6.00	0.30-0.70				○	●	●															
	SNMG120416-AG	2.50-6.00	0.40-0.70				○	●	●															
	SNMG150612-AG	2.15-6.40	0.25-0.50				○	●	●															
	SNMG190612-AG	2.15-6.40	0.25-0.50				○	●	●															
	SNMG190616-AG	2.85-7.60	0.30-0.65				○	●	●															

Note: ●Recommended grade ready to stock



## Negative Inserts

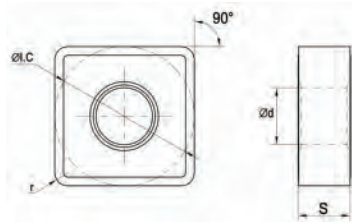

Length	Size(mm)			
	IC	S	d	r
19	19.05	6.35	7.94	1.2-2.4
25	25.4	7.94-9.52	9.12	2.4-3.2

### 90° SNMM With Hole

Shape	Type	ap (mm)	f (mm/rev)	Grade																		
				CVD						PVD												
				GW0203	GW0403	GW1153	GW2134	GW2234	GW2354	GW0251	GW5251	GW8251	GW8241	GW8281	GWR6101	GWR5251						
 P Heavy-duty	SNMM190612-AG	2.40-9.50	0.25-0.60				○	●	●													
	SNMM190616-AG	3.20-9.50	0.35-0.80				○	●	●													
	SNMM190624-AG	4.80-9.50	0.53-1.20				○	●	●													
	SNMM250724-AG	4.80-12.70	0.53-1.20				○	●	●													
	SNMM250732-AG	4.80-12.70	0.53-1.20				○	●	●													
	SNMM250924-AG	4.35-12.70	0.53-1.20				○	●	●													
	SNMM250932-AG	4.35-12.70	0.53-1.20				○	●	●													

Note: ●Recommended grade ready to stock

## Negative Inserts

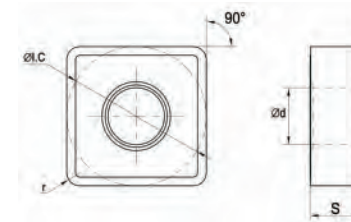

Length	Size(mm)			
	IC	S	d	r
12	12.7	4.76	5.16	0.4-1.2

### 90° SNMG With Hole

Shape	Type	ap (mm)	f (mm/rev)	Grade																			
				CVD						PVD													
				GW0203	GW0403	GW1153	GW2134	GW2234	GW2354	GW0251	GW5251	GW8251	GW8241	GW8281	GWR6101	GWR5251							
 M Finishing	SNMG120404-BF	0.25-3.20	0.05-0.15																				
	SNMG120408-BF	0.50-3.20	0.10-0.30																				
	SNMG120412-BF	0.75-3.20	0.15-0.45																				

Note: ●Recommended grade ready to stock



## Negative Inserts

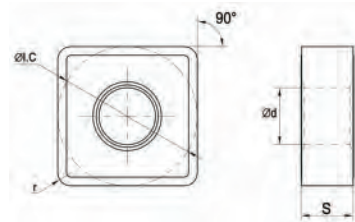

Length	Size(mm)			
	IC	S	d	r
12	12.7	4.76	5.16	0.4-1.2
15	15.875	6.35	6.35	0.8-1.2

### 90° SNMG With Hole

Shape	Type	ap (mm)	f (mm/rev)	Grade																					
				CVD						PVD															
				GW0203	GW0403	GW1153	GW2134	GW2234	GW2354	GW0251	GW5251	GW8251	GW8241	GW8281	GWR6101	GWR5251									
 M Semi-finishing	SNMG120404-BM	0.30-4.20	0.08-0.25																						
	SNMG120408-BM	0.65-4.20	0.15-0.45																						
	SNMG120412-BM	0.95-4.20	0.25-0.65																						
	SNMG150608-BM	0.65-5.20	0.15-0.45																						
	SNMG150612-BM	0.95-5.20	0.25-0.65																						

Note: ● Recommended grade ready to stock

## Negative Inserts

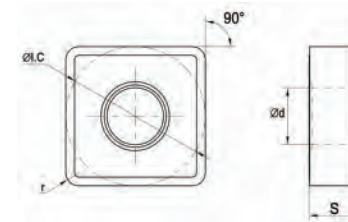

Length	Size(mm)			
	IC	S	d	r
12	12.7	4.76	5.16	0.4-1.2
15	15.875	6.35	6.35	0.8-1.2

### 90° SNMG With Hole

Shape	Type	ap (mm)	f (mm/rev)	Grade																					
				CVD						PVD															
				GW0203	GW0403	GW1153	GW2134	GW2234	GW2354	GW0251	GW5251	GW8251	GW8241	GW8281	GWR6101	GWR5251									
 M Roughing	SNMG120404-BR	0.30-4.20	0.08-0.25																						
	SNMG120408-BR	0.65-4.20	0.15-0.45																						
	SNMG120412-BR	0.95-4.20	0.23-0.66																						
	SNMG150608-BR	0.65-5.20	0.15-0.44																						
	SNMG150612-BR	0.95-5.20	0.23-0.66																						

Note: ● Recommended grade ready to stock



## Negative Inserts

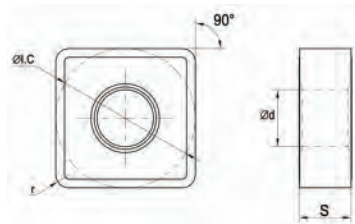

Length	Size(mm)			
	IC	S	d	r
12	12.7	4.76	5.16	0.4-1.6
15	15.875	6.35	6.35	0.8-1.6
19	19.05	6.35	7.94	1.2-1.6

### 90° SNMG With Hole

Shape	Type	ap (mm)	f (mm/rev)	Grade																				
				CVD						PVD														
				GW0203	GW0403	GW1153	GW2134	GW2234	GW2354	GW0251	GW5251	GW8251	GW8241	GW8281	GWR6101	GWR5251								
 K Semi-finishing	SNMG120404-CM	0.40-4.20	0.08-0.25			●	○	○																
	SNMG120408-CM	0.80-4.20	0.15-0.45			●	○	○																
	SNMG120412-CM	1.20-4.20	0.25-0.65			●	○	○																

Note: ●Recommended grade ready to stock

## Negative Inserts

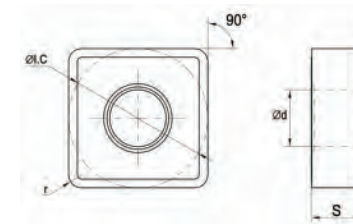

Length	Size(mm)			
	IC	S	d	r
12	12.7	4.76	5.16	0.4-1.6
15	15.875	6.35	6.35	0.8-1.6

### 90° SNMG With Hole

Shape	Type	ap (mm)	f (mm/rev)	Grade																			
				CVD						PVD													
				GW0203	GW0403	GW1153	GW2134	GW2234	GW2354	GW0251	GW5251	GW8251	GW8241	GW8281	GWR6101	GWR5251							
 S Semi-finishing	SNMG120404-DM	0.40-3.90	0.08-0.25																				
	SNMG120408-DM	0.80-3.90	0.15-0.45																				
	SNMG120412-DM	1.20-3.90	0.25-0.65																				
	SNMG120416-DM	1.80-3.90	0.30-0.90																				
	SNMG150608-DM	0.80-3.90	0.15-0.45																				
	SNMG150612-DM	1.20-3.90	0.25-0.65																				
	SNMG150616-DM	1.80-3.90	0.30-0.90																				

Note: ●Recommended grade ready to stock



## Negative Inserts

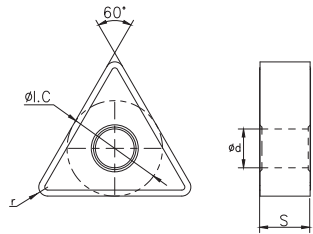

Length	Size(mm)			
	IC	S	d	r
16	9.525	4.76	3.81	0.4-1.2

60° TNMG With Hole

Shape	Type	ap (mm)	f (mm/rev)	Grade																				
				CVD						PVD														
				GW0203	GW0403	GW1153	GW2134	GW2234	GW2354	GW0251	GW5251	GW8251	GW8241	GW8281	GWR6101	GWR5251								
 P Finishing	TNMG160404-AF	0.26-3.1	0.05-0.15				●	○																
	TNMG160408-AF	0.52-3.1	0.10-0.30				●	○																
	TNGG160412-AF	0.78-3.1	0.15-0.45				●	○																

Note: ●Recommended grade ready to stock

## Negative Inserts

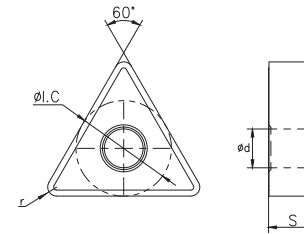

Length	Size(mm)			
	IC	S	d	r
16	9.525	4.76	3.81	0.4-1.2
22	12.7	4.76	5.16	0.8-1.6

60° TNMG With Hole

Shape	Type	ap (mm)	f (mm/rev)	Grade																			
				CVD						PVD													
				GW0203	GW0403	GW1153	GW2134	GW2234	GW2354	GW0251	GW5251	GW8251	GW8241	GW8281	GWR6101	GWR5251							
 P Semi-finishing	TNMG160404-AS	0.60-5.80	0.10-0.30				○	●	○														
	TNMG160408-AS	1.20-5.80	0.20-0.60				○	●	○														
	TNMG160412-AS	1.80-5.80	0.30-0.90				○	●	○														
	TNMG220408-AS	1.20-7.70	0.20-0.60				○	●	○														
	TNMG220412-AS	1.80-7.70	0.30-0.90				○	●	○														
	TNMG220416-AS	2.40-7.70	0.40-1.20				○	●	○														

Note: ●Recommended grade ready to stock



## Negative Inserts

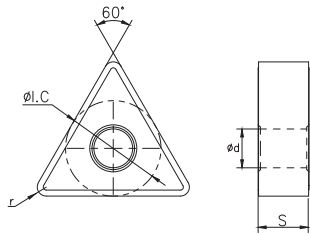

Length	Size(mm)			
	IC	S	d	r
16	9.525	4.76	3.81	0.4-1.2
22	12.7	4.76	5.16	0.8-1.6

60° TNMG With Hole

Shape	Type	ap (mm)	f (mm/rev)	Grade																			
				CVD						PVD													
				GW0203	GW0403	GW1153	GW2134	GW2234	GW2354	GW0251	GW5251	GW8251	GW8241	GW8281	GWR6101	GWR5251							
 P Medium machining	TNMG160404-AM	0.4-5.0	0.10-0.30				○	●	○														
	TNMG160408-AM	0.5-5.0	0.15-0.50				○	●	○														
	TNMG160412-AM	0.8-5.0	0.18-0.60				○	●	○														
	TNMG220408-AM	0.8-6.6	0.15-0.50				○	●	○														
	TNMG220412-AM	0.5-6.0	0.18-0.60				○	●	○														
	TNMG220416-AM	1.0-6.0	0.23-0.65				○	●	○														

Note: ●Recommended grade ready to stock

## Negative Inserts

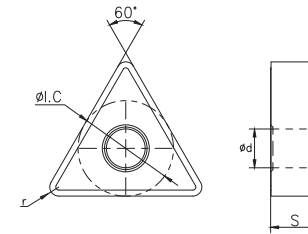

Length	Size(mm)			
	IC	S	d	r
16	9.525	4.76	3.81	0.8-1.2
22	12.7	4.76	5.16	0.8-1.6

60° TNMG With Hole

Shape	Type	ap (mm)	f (mm/rev)	Grade																			
				CVD						PVD													
				GW0203	GW0403	GW1153	GW2134	GW2234	GW2354	GW0251	GW5251	GW8251	GW8241	GW8281	GWR6101	GWR5251							
 P Roughing	TNMG160408-AG	2.00-5.00	0.25-0.65				○	●	●														
	TNMG220408-AG	2.50-7.00	0.25-0.65				○	●	●														
	TNMG220412-AG	2.50-7.00	0.25-0.65				○	●	●														

Note: ●Recommended grade ready to stock





## Negative Inserts

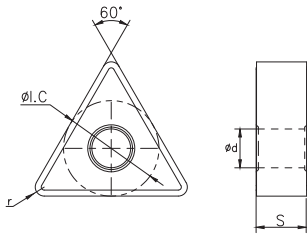

Length	Size(mm)			
	IC	S	d	r
16	9.525	4.76	3.81	0.4-1.2
22	12.7	4.76	5.16	0.8-1.6

60° TNMG With Hole

Shape	Type	ap (mm)	f (mm/rev)	Grade													
				CVD						PVD							
				GW0203	GW0403	GW1153	GW2134	GW2234	GW2354	GW0251	GW5251	GW8251	GW8241	GW8281	GWR6101	GWR5251	
 K Semi-finishing	TNMG160404-CM	0.40-4.10	0.08-0.25			●	○	○									
	TNMG160408-CM	0.80-4.10	0.15-0.45			●	○	○									
	TNMG160412-CM	1.20-4.10	0.25-0.65			●	○	○									
	TNMG220412-CM	1.20-4.90	0.25-0.65			●	○	○									

Note: ●Recommended grade ready to stock

## Negative Inserts

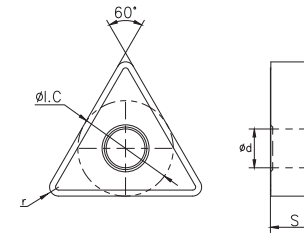

Length	Size(mm)			
	IC	S	d	r
16	9.525	4.76	3.81	0.4-1.2
22	12.7	4.76	5.16	0.8-1.2

60° TNMG With Hole

Shape	Type	ap (mm)	f (mm/rev)	Grade													
				CVD						PVD							
				GW0203	GW0403	GW1153	GW2134	GW2234	GW2354	GW0251	GW5251	GW8251	GW8241	GW8281	GWR6101	GWR5251	
 M Roughing	TNMG160404-BR	0.30-4.10	0.08-0.25									○	○		○	●	
	TNMG160408-BR	0.65-4.10	0.15-0.45									○	○		○	●	
	TNMG160412-BR	0.95-4.10	0.25-0.65									○	○		○	●	
	TNMG220408-BR	0.65-4.90	0.15-0.45									○	○		○	●	
	TNMG220412-BR	0.95-4.90	0.25-0.65									○	○		○	●	

Note: ●Recommended grade ready to stock



## Negative Inserts

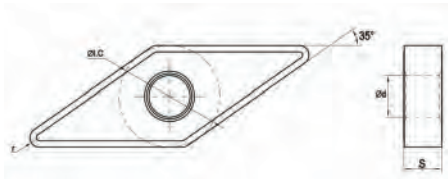

Length	Size(mm)			
	IC	S	d	r
16	9.525	4.76	3.81	0.4-1.2

### 35° VNMG With Hole

Shape	Type	ap (mm)	f (mm/rev)	Grade																				
				CVD						PVD														
				GW0203	GW0403	GW1153	GW2134	GW2234	GW2354	GW0251	GW5251	GW8251	GW8241	GW8281	GWR6101	GWR5251								
	VNMG160404-CM	0.40-3.30	0.08-0.25			●	○	○																
	VNMG160408-CM	0.80-3.30	0.15-0.45			●	○	○																
	VNMG160412-CM	1.20-3.30	0.25-0.65			●	○	○																
K Semi-finishing																								

Note: ●Recommended grade ready to stock

## Negative Inserts

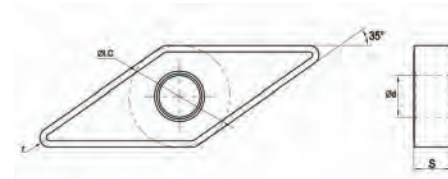

Length	Size(mm)			
	IC	S	d	r
16	9.525	4.76	3.81	0.4-1.2

### 35° VNMG With Hole

Shape	Type	ap (mm)	f (mm/rev)	Grade																				
				CVD						PVD														
				GW0203	GW0403	GW1153	GW2134	GW2234	GW2354	GW0251	GW5251	GW8251	GW8241	GW8281	GWR6101	GWR5251								
	VNMG160404-AF	0.26-2.1	0.05-0.15				●	○																
	VNMG160408-AF	0.52-2.1	0.10-0.30				●	○																
	VNMG160412-AF	0.78-2.1	0.15-0.45				●	○																
P Finishing																								

Note: ●Recommended grade ready to stock



## Negative Inserts

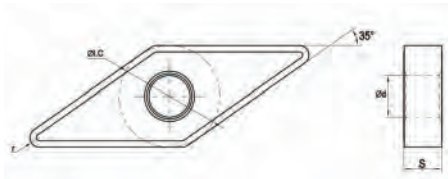

Length	Size(mm)			
	IC	S	d	r
11	6.35	4.76	2.26	0.4-0.8
16	9.525	4.76	3.81	0.4-0.8

### 35° VNMG With Hole

Shape	Type	ap (mm)	f (mm/rev)	Grade																			
				CVD						PVD													
				GW0203	GW0403	GW1153	GW2134	GW2234	GW2354	GW0251	GW5251	GW8251	GW8241	GW8281	GWR6101	GWR5251							
P Semi-finishing	VNMG110404-AS	0.80-2.50	0.15-0.36				○	●	○														
	VNMG110408-AS	1.00-2.50	0.17-0.36				○	●	○														
	VNMG160404-AS	0.80-3.00	0.15-0.36				○	●	○														
	VNMG160408-AS	1.00-2.50	0.17-0.36				○	●	○														

Note: ●Recommended grade ready to stock

## Negative Inserts

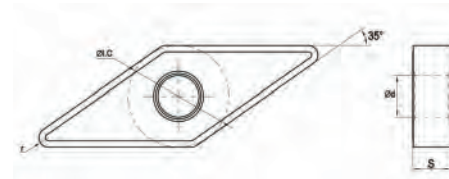

Length	Size(mm)			
	IC	S	d	r
11	6.35	4.76	2.26	0.4-0.8
16	9.525	4.76	3.81	0.4-0.8

### 35° VNMG With Hole

Shape	Type	ap (mm)	f (mm/rev)	Grade																			
				CVD						PVD													
				GW0203	GW0403	GW1153	GW2134	GW2234	GW2354	GW0251	GW5251	GW8251	GW8241	GW8281	GWR6101	GWR5251							
P Medium machining	VNMG160408-AM	0.5 - 4.0	0.15 - 0.5				○	●	○														
	VNMG160412-AM	0.8 - 4.0	0.18 - 0.6				○	●	○														

Note: ●Recommended grade ready to stock



## Negative Inserts

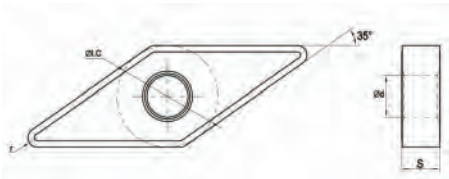

Length	Size(mm)			
	IC	S	d	r
16	9.525	4.76	3.81	0.4-1.2

35° VNMG With Hole

Shape	Type	ap (mm)	f (mm/rev)	Grade													
				CVD						PVD							
				GW0203	GW0403	GW1153	GW2134	GW2234	GW2354	GW0251	GW5251	GW8251	GW8241	GW8281	GWR6101	GWR5251	
M Finishing	VNMG160404-BF	0.25-3.30	0.05-0.15							○	●	○	●				
	VNMG160408-BF	0.55-3.30	0.10-0.30							○	●	○	●				
	VNMG160412-BF	0.75-3.30	0.15-0.45							○	●	○	●				

Note: ● Recommended grade ready to stock

## Negative Inserts

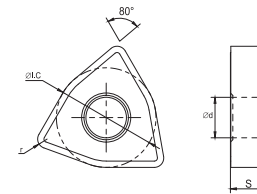

Length	Size(mm)			
	IC	S	d	r
8	12.7	4.76	5.16	0.4-1.2

80° WNMG With Hole

Shape	Type	ap (mm)	f (mm/rev)	Grade													
				CVD						PVD							
				GW0203	GW0403	GW1153	GW2134	GW2234	GW2354	GW0251	GW5251	GW8251	GW8241	GW8281	GWR6101	GWR5251	
P Finishing	WNMG080404-AF	0.26-2.2	0.05-0.15														
	WNMG080408-AF	0.52-2.2	0.10-0.30														
	WNMG080412-AF	0.78-2.2	0.15-0.45														

Note: ● Recommended grade ready to stock



## Negative Inserts

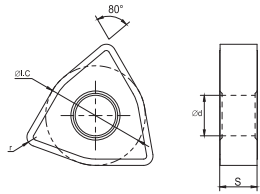

Length	Size(mm)			
	IC	S	d	r
8	12.7	4.76	5.16	0.4-1.6

80° WNMG With Hole

Shape	Type	ap (mm)	f (mm/rev)	Grade															
				CVD						PVD									
				GW0203	GW0403	GW1153	GW2134	GW2234	GW2354	GW0251	GW5251	GW8251	GW8241	GW8281	GWR6101	GWR5251			
 P Semi-finishing	WNMG080404-AS	0.60-4.30	0.10-0.30				○	●	○										
	WNMG080408-AS	1.20-4.30	0.20-0.60				○	●	○										
	WNMG080412-AS	1.80-4.30	0.30-0.90				○	●	○										
	WNMG080416-AS	2.40-4.30	0.40-1.20				○	●	○										

Note: ● Recommended grade ready to stock

## Negative Inserts

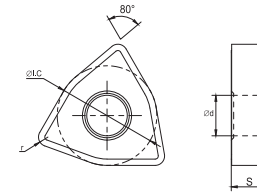

Length	Size(mm)			
	IC	S	d	r
8	12.7	4.76	5.16	0.4-1.6

80° WNMG With Hole

Shape	Type	ap (mm)	f (mm/rev)	Grade															
				CVD						PVD									
				GW0203	GW0403	GW1153	GW2134	GW2234	GW2354	GW0251	GW5251	GW8251	GW8241	GW8281	GWR6101	GWR5251			
 P Medium machining	WNMG080404-AM	0.25-3.0	0.10-0.40				○	●	○										
	WNMG080408-AM	0.50-4.0	0.15-0.50				○	●	○										
	WNMG080412-AM	0.80-4.0	0.18-0.60				○	●	○										
	WNMG080416-AM	0.80-6.6	0.23-0.65				○	●	○										

Note: ● Recommended grade ready to stock



## Negative Inserts

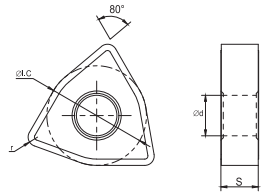

Length	Size(mm)			
	IC	S	d	r
6	9.525	4.76	3.81	0.8-1.2
8	12.7	4.76	5.16	0.8-1.2

80° WNMG With Hole

Shape	Type	ap (mm)	f (mm/rev)	Grade													
				CVD						PVD							
				GW0203	GW0403	GW1153	GW2134	GW2234	GW2354	GW0251	GW5251	GW8251	GW8241	GW8281	GWR6101	GWR5251	
 P Roughing	WNMG060408-AG	0.80-4.00	0.15-0.50				○	●	●								
	WNMG060412-AG	0.80-4.00	0.15-0.50				○	●	●								
	WNMG080408-AG	0.80-4.50	0.15-0.55				○	●	●								
	WNMG080412-AG	0.80-4.50	0.20-0.55				○	●	●								

Note: ●Recommended grade ready to stock

## Negative Inserts

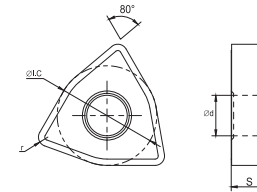

Length	Size(mm)			
	IC	S	d	r
6	9.525	4.76	3.81	0.4-0.8
8	12.7	4.76	5.16	0.4-1.6

80° WNMG With Hole

Shape	Type	ap (mm)	f (mm/rev)	Grade													
				CVD						PVD							
				GW0203	GW0403	GW1153	GW2134	GW2234	GW2354	GW0251	GW5251	GW8251	GW8241	GW8281	GWR6101	GWR5251	
 M Finishing	WNMG060404-BF	0.25-2.40	0.05-0.15											○	●	○	●
	WNMG060408-BF	0.50-2.40	0.10-0.30											○	●	○	●
	WNMG080404-BF	0.25-3.20	0.05-0.15											○	●	○	●
	WNMG080408-BF	0.50-3.20	0.10-0.30											○	●	○	●
	WNMG080412-BF	0.75-3.20	0.15-0.45											○	●	○	●
	WNMG080416-BF	1.05-3.20	0.20-0.60											○	●	○	●

Note: ●Recommended grade ready to stock



## Negative Inserts

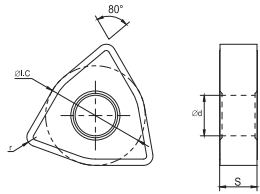

Length	Size(mm)			
	IC	S	d	r
6	9.525	4.76	3.81	0.4-0.8
8	12.7	4.76	5.16	0.4-1.6

80° WNMG With Hole

Shape	Type	ap (mm)	f (mm/rev)	Grade												
				CVD						PVD						
				GW0203	GW0403	GW1153	GW2134	GW2234	GW2354	GW0251	GW5251	GW8251	GW8241	GW8281	GWR6101	GWR5251
M Semi-finishing	WNMG060404-BM	0.30-2.10	0.10-0.30							○	○	○	●			
	WNMG060408-BM	0.65-2.10	0.15-0.45							○	○	○	●			
	WNMG080404-BM	0.30-2.90	0.10-0.30							○	○	○	●			
	WNMG080408-BM	0.65-2.90	0.15-0.45							○	○	○	●			
	WNMG080412-BM	0.95-2.90	0.20-0.60							○	○	○	●			
	WNMG080416-BM	1.25-2.90	0.25-0.75							○	○	○	●			

Note: ●Recommended grade ready to stock

## Negative Inserts

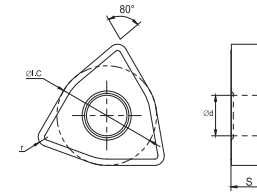

Length	Size(mm)			
	IC	S	d	r
6	9.525	4.76	3.81	0.4-0.8
8	12.7	4.76	5.16	0.4-1.6

80° WNMG With Hole

Shape	Type	ap (mm)	f (mm/rev)	Grade																		
				CVD						PVD												
				GW0203	GW0403	GW1153	GW2134	GW2234	GW2354	GW0251	GW5251	GW8251	GW8241	GW8281	GWR6101	GWR5251						
M Roughing	WNMG060404-BR	0.30-2.10	0.10-0.30												○	○		○	●			
	WNMG060408-BR	0.65-2.10	0.15-0.45												○	○		○	●			
	WNMG080404-BR	0.30-2.90	0.10-0.30												○	○		○	●			
	WNMG080408-BR	0.65-2.90	0.15-0.45												○	○		○	●			
	WNMG080412-BR	0.95-2.90	0.20-0.60												○	○		○	●			
	WNMG080416-BR	1.25-2.90	0.25-0.75												○	○		○	●			

Note: ●Recommended grade ready to stock



## Negative Inserts

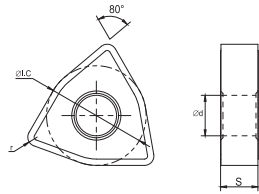

Length	Size(mm)			
	IC	S	d	r
8	12.7	4.76	5.16	0.4-1.6

80° WNMG With Hole

Shape	Type	ap (mm)	f (mm/rev)	Grade														
				CVD						PVD								
				GW0203	GW0403	GW1153	GW2134	GW2234	GW2354	GW0251	GW5251	GW8251	GW8241	GW8281	GWR6101	GWR5251		
 K Semi-finishing	WNMG080404-CM	0.08-0.25	0.40-2.90			●	○	○										
	WNMG080408-CM	0.15-0.45	0.80-2.90			●	○	○										
	WNMG080412-CM	0.25-0.66	1.20-2.90			●	○	○										

Note: ●Recommended grade ready to stock

## Negative Inserts

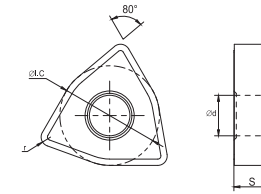

Length	Size(mm)			
	IC	S	d	r
8	12.7	4.76	5.16	0.4-1.6

80° WNMG With Hole

Shape	Type	ap (mm)	f (mm/rev)	Grade													
				CVD				PVD									
				GW1153	GW2134	GW2234	GW2354	GW0251	GW5251	GW8251	GW8241	GW8281	GW6051	GW5101	GWR6101	GWR5251	
 S Semi-finishing	WNMG080404-DM	0.40-4.30	0.08-0.25							○			○		●	○	●
	WNMG080408-DM	0.80-4.30	0.15-0.45							○			○		●	○	●
	WNMG080412-DM	1.20-4.30	0.25-0.66							○			○		●	○	●
	WNMG080416-DM	1.60-4.30	0.30-0.90							○			○		●	○	●

Note: ●Recommended grade ready to stock



## Positive Inserts

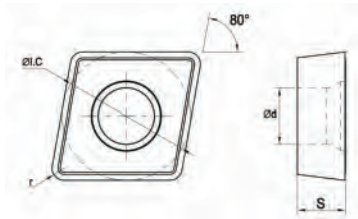

Length	Size(mm)			
	IC	S	d	r
6	3.65	2.38	2.8	0.4-0.8
9	9.525	3.97	4.4	0.4-0.8
12	12.7	4.76	5.56	0.4-1.2

80° CCMT With Hole

Shape	Type	ap (mm)	f (mm/rev)	Grade													
				CVD				PVD									
				GW1153	GW2134	GW2234	GW2354	GW0251	GW5251	GW8251	GW8241	GW8281	GW6051	GW5101	GWR6101	GWR5251	
General Semi-finishing	CCMT060204-GM	0.40-2.10	0.05-0.18	●	●		○		●	○							○
	CCMT060208-GM	0.80-2.10	0.10-0.35	●	●		○		●	○							○
	CCMT09T304-GM	0.40-3.80	0.05-0.18	●	●		○		●	○							○
	CCMT09T308-GM	0.80-3.20	0.10-0.35	●	●		○		●	○							○
	CCMT120404-GM	0.40-4.30	0.05-0.18	●	●		○		●	○							○
	CCMT120408-GM	0.80-4.30	0.10-0.35	●	●		○		●	○							○
	CCMT120412-GM	1.20-4.30	0.15-0.55	●	●		○		●	○							○

Note: ●Recommended grade ready to stock

## Positive Inserts

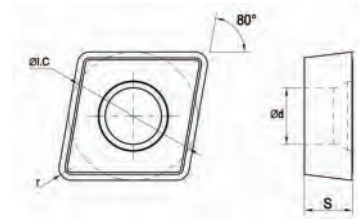

Length	Size(mm)			
	IC	S	d	r
6	3.65	2.38	2.8	0.4-0.8
9	9.525	3.97	4.4	0.4-0.8

80° CCMT With Hole

Shape	Type	ap (mm)	f (mm/rev)	Grade																	
				CVD				PVD													
				GW0203	GW0403	GW1153	GW2134	GW2234	GW2354	GW0251	GW5251	GW8251	GW8241	GW8281	GWR6101	GWR5251					
M Finishing	CCMT060204-GF	0.30-1.60	0.05-0.15													○	●	○	●		
	CCMT060208-GF	0.60-1.60	0.10-0.30													○	●	○	●		
	CCMT09T304-GF	0.30-2.20	0.05-0.15													○	●	○	●		
	CCMT09T308-GF	0.60-2.40	0.10-0.30													○	●	○	●		

Note: ●Recommended grade ready to stock



## Positive Inserts

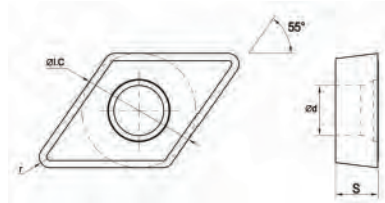

Length	Size(mm)			
	IC	S	d	r
7	6.35	2.38	2.8	0.4-0.8
11	9.525	3.97	4.4	0.4-1.2

55° DCMT With Hole

Shape	Type	ap (mm)	f (mm/rev)	Grade												
				CVD				PVD								
				GW1153	GW2134	GW2234	GW2354	GW0251	GW5251	GW8251	GW8241	GW8281	GW6051	GW5101	GWR6101	GWR5251
	DCMT070204-GM	0.40-2.30	0.05-0.20	●	●		○	●	○							○
	DCMT070208-GM	0.80-2.30	0.10-0.35	●	●		○	●	○							○
	DCMT11T304-GM	0.40-3.50	0.05-0.20	●	●		○	●	○							○
	DCMT11T308-GM	0.80-3.50	0.20-0.35	●	●		○	●	○							○
	DCMT11T312-GM	1.20-3.50	0.25-0.55	●	●		○	●	○							○
General Semi-finishing																

Note: ●Recommended grade ready to stock

## Positive Inserts

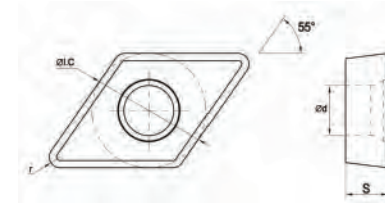

Length	Size(mm)			
	IC	S	d	r
7	6.35	2.38	2.8	0.4-0.8
11	9.525	3.97	4.4	0.4-1.2

55° DCMT With Hole

Shape	Type	ap (mm)	f (mm/rev)	Grade														
				CVD				PVD										
				GW0203	GW0403	GW1153	GW2134	GW2234	GW2354	GW0251	GW5251	GW8251	GW8241	GW8281	GWR6101	GWR5251		
	DCMT070204-GF	0.30-1.50	0.05-0.15										○	●	○	●		
	DCMT070208-GF	0.60-1.50	0.05-0.20										○	●	○	●		
	DCMT11T304-GF	0.30-2.30	0.02-0.10										○	●	○	●		
	DCMT11T308-GF	0.60-2.30	0.05-0.26										○	●	○	●		
	DCMT11T312-GF	0.90-2.30	0.20-0.30										○	●	○	●		
	M Finishing																	

Note: ●Recommended grade ready to stock



## Positive Inserts

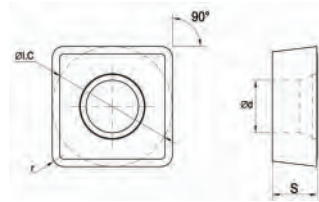

Length	Size(mm)			
	IC	S	d	r
9	9.525	3.97	4.4	0.4-0.8
12	12.7	4.76	5.56	0.4-1.2

90° SCMT With Hole

Shape	Type	ap (mm)	f (mm/rev)	Grade													
				CVD				PVD									
				GW1153	GW2134	GW2234	GW2354	GW0251	GW5251	GW8251	GW8241	GW8281	GW6051	GW5101	GWR6101	GWR5251	
	SCMT09T304-GM	0.40-3.10	0.05-0.20	●	●		○		●	○							○
	SCMT09T308-GM	0.80-3.10	0.10-0.35	●	●		○		●	○							○
	SCMT120404-GM	0.40-4.20	0.05-0.20	●	●		○		●	○							○
	SCMT120408-GM	0.80-4.20	0.10-0.30	●	●		○		●	○							○
	SCMT120412-GM	1.20-4.20	0.15-0.55	●	●		○		●	○							○
General Semi-finishing																	

Note: ●Recommended grade ready to stock

## Positive Inserts

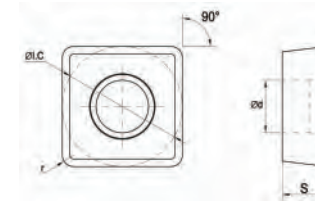

Length	Size(mm)			
	IC	S	d	r
9	9.525	3.97	4.4	0.4-0.8

90° SCMT With Hole

Shape	Type	ap (mm)	f (mm/rev)	Grade																		
				CVD				PVD														
				GW0203	GW0403	GW1153	GW2134	GW2234	GW2354	GW0251	GW5251	GW8251	GW8241	GW8281	GWR6101	GWR5251						
	SCMT09T304-GF	0.30-2.40	0.05-0.15													○	●	○	●			
	SCMT09T308-GF	0.60-2.40	0.10-0.30													○	●	○	●			
M Finishing																						

Note: ●Recommended grade ready to stock



## Positive Inserts

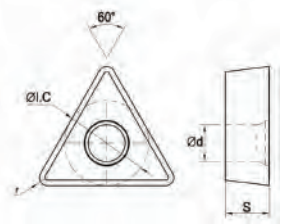

Length	Size(mm)			
	IC	S	d	r
9	5.56	2.38	2.2	0.4-0.8
11	6.35	2.38	2.8	0.4-1.2
16	9.525	3.97	4.4	0.4-1.2

60° TCMT With Hole

Shape	Type	ap (mm)	f (mm/rev)	Grade													
				CVD				PVD									
				GW1153	GW2134	GW2234	GW2354	GW0251	GW5251	GW8251	GW8241	GW8281	GW6051	GW5101	GWR6101	GWR5251	
 General Semi-finishing	TCMT090204-GM	0.40-2.90	0.05-0.20		●	●		○		●	○						○
	TCMT090208-GM	0.80-2.90	0.10-0.35		●	●		○		●	○						○
	TCMT110204-GM	0.40-3.30	0.05-0.20		●	●		○		●	○						○
	TCMT110208-GM	0.80-3.30	0.10-0.35		●	●		○		●	○						○
	TCMT110212-GM	1.20-3.30	0.15-0.55		●	●		○		●	○						○
	TCMT16T304-GM	0.40-4.90	0.05-0.20		●	●		○		●	○						○
	TCMT16T308-GM	0.80-4.90	0.10-0.35		●	●		○		●	○						○
	TCMT16T312-GM	1.20-4.90	0.15-0.55		●	●		○		●	○						○

Note: ●Recommended grade ready to stock

## Positive Inserts

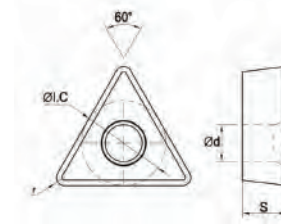

Length	Size(mm)			
	IC	S	d	r
9	5.56	2.38	2.2	0.4-0.8
11	6.35	2.38	2.8	0.4-1.2
16	9.525	3.97	4.4	0.4-1.2

60° TCMT With Hole

Shape	Type	ap (mm)	f (mm/rev)	Grade															
				CVD				PVD											
				GW0203	GW0403	GW1153	GW2134	GW2234	GW2354	GW0251	GW5251	GW8251	GW8241	GW8281	GWR6101	GWR5251			
 M Finishing	TCMT090204-GF	0.30-1.80	0.05-0.15											○	●	○	●		
	TCMT090208-GF	0.60-2.20	0.10-0.30											○	●	○	●		
	TCMT110204-GF	0.30-2.20	0.05-0.15											○	●	○	●		
	TCMT110208-GF	0.60-3.30	0.10-0.30											○	●	○	●		
	TCMT110212-GF	1.20-3.30	0.20-0.40											○	●	○	●		
	TCMT16T304-GF	0.30-3.30	0.05-0.15											○	●	○	●		
	TCMT16T308-GF	0.60-3.30	0.10-0.30											○	●	○	●		
	TCMT16T312-GF	1.20-3.30	0.10-0.40											○	●	○	●		

Note: ●Recommended grade ready to stock



# For Small-Parts

GREWIN&COWEE  
CUTTING TOOLS



Processing Sword for CNC Precision Automatic Lathe--  
High Precision and High-quality Guarantee

### Negative Inserts

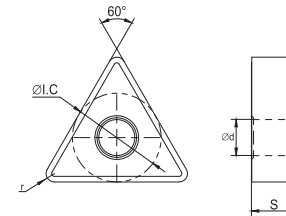

Length	Size(mm)			
	IC	S	d	r
16	9.525	4.76	3.81	0.1-0.4

### 60° TNGG With Hole

Shape	Type	ap (mm)	f (mm/rev)	Grade														
				CVD						PVD								
				GW0203	GW0403	GW1153	GW2134	GW2234	GW2354	GW0251	GW5251	GW8251	GW8241	GW8281	GWR6101	GWR5251		
	TNGG160401-FS	0.4-1.5	0.02-0.06									○	●	●	○			
	TNGG160402-FS	0.6-2.0	0.04-0.08									○	●	●	○			
	TNGG160404-FS	0.8-2.5	0.06-0.10									○	●	●	○			
Small Parts Machining																		

Note: ●Recommended grade ready to stock



## Negative Inserts

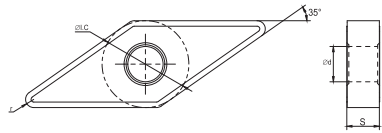

Length	Size(mm)			
	IC	S	d	r
16	6.35	4.76	3.81	0.2-0.8

### 35° VNGG With Hole

Shape	Type	ap (mm)	f (mm/rev)	Grade													
				CVD						PVD							
				GW0203	GW0403	GW1153	GW2134	GW2234	GW2354	GW0251	GW5251	GW8251	GW8241	GW8281	GWR6101	GWR5251	
	VNGG160402-FS	0.4-2.0	0.02-0.06							○	●	●	○				
	VNGG160404-FS	0.8-2.5	0.04-0.08							○	●	●	○				
	VNGG160408-FS	1.0-3.0	0.06-0.12							○	●	●	○				
Small Parts Machining																	

Note: ●Recommended grade ready to stock

## Positive Inserts

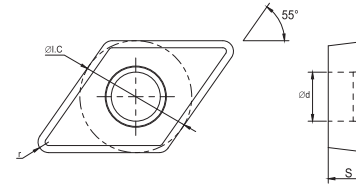

Length	Size(mm)			
	IC	S	d	r
9	9.525	3.97	4.4	0.1-0.8

### 55° DCGT With Hole

Shape	Type	ap (mm)	f (mm/rev)	Grade															
				CVD						PVD									
				GW0203	GW0403	GW1153	GW2134	GW2234	GW2354	GW0251	GW5251	GW8251	GW8241	GW8281	GWR6101	GWR5251			
	DCGT11T301-FS	0.10-1.50	0.02-0.06											○	●	●	○		
	DCGT11T302-FS	0.20-2.00	0.05-0.12											○	●	●	○		
	DCGT11T304-FS	0.20-2.50	0.08-0.25											○	●	●	○		
	DCGT11T308-FS	0.30-3.00	0.10-0.30											○	●	●	○		
Small Parts Machining																			

Note: ●Recommended grade ready to stock



## Positive Inserts

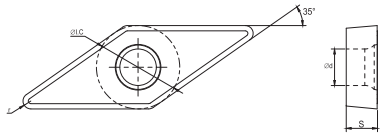

Length	Size(mm)			
	IC	S	d	r
11	6.35	3.18	2.81	0.1-0.4

### 35° VBGT With Hole

Shape	Type	ap (mm)	f (mm/rev)	Grade													
				CVD						PVD							
				GW0203	GW0403	GW1153	GW2134	GW2234	GW2354	GW6051	GW8201	GW6251	GW8301	GW8281	GWR6101	GWR5251	
 Small Parts Machining	VBGT110301-FS	0.1-1.5	0.02-0.06							○	●	●	○				
	VBGT110302-FS	0.2-2.0	0.05-0.12							○	●	●	○				
	VBGT110304-FS	0.2-2.5	0.08-0.25							○	●	●	○				

Note: ●Recommended grade ready to stock

## Positive Inserts

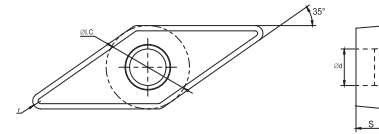

Length	Size(mm)			
	IC	S	d	r
11	6.35	3.18	2.81	0.1-0.4

### 35° VCGT With Hole

Shape	Type	ap (mm)	f (mm/rev)	Grade													
				CVD						PVD							
				GW0203	GW0403	GW1153	GW2134	GW2234	GW2354	GW6051	GW8201	GW6251	GW8301	GW8281	GWR6101	GWR5251	
 Small Parts Machining	VCGT110301-FS	0.1-1.5	0.02-0.06							○	●	●	○				
	VCGT110302-FS	0.2-2.0	0.05-0.12							○	●	●	○				
	VCGT110304-FS	0.2-2.5	0.08-0.25							○	●	●	○				

Note: ●Recommended grade ready to stock



## Positive Inserts

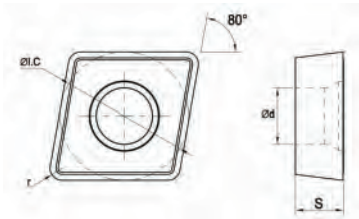

Length	Size(mm)			
	IC	S	d	r
9	9.525	3.97	4.4	0.1
9	9.525	3.97	4.4	0.2
9	9.525	3.97	4.4	0.4

80° CCGT With Hole

Shape	Type	ap (mm)	f (mm/rev)	Grade																				
				CVD						PVD														
				GW0203	GW0403	GW1153	GW2134	GW2234	GW2354	GW6051	GW8201	GW6251	GW8301	GW8281	GWR6101	GWR5251								
Small Parts Machining	CCGT09T301R/L-UF	0.1-1.5	0.05-0.15							○	●	●	○											
	CCGT09T302R/L-UF	0.2-2	0.05-0.2							○	●	●	○											
	CCGT09T304R/L-UF	0.4-2.5	0.05-0.25							○	●	●	○											

Note: ●Recommended grade ready to stock

## Positive Inserts

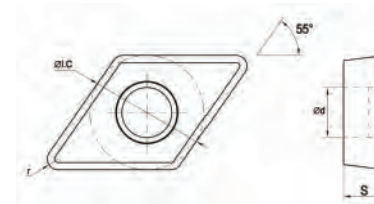

Length	Size(mm)			
	IC	S	d	r
7	6.35	2.38	2.8	0.05-0.2
11	9.525	3.97	4.4	0.1-0.2

55° DCGT With Hole

Shape	Type	ap (mm)	f (mm/rev)	Grade																				
				CVD						PVD														
				GW0203	GW0403	GW1153	GW2134	GW2234	GW2354	GW6051	GW8201	GW6251	GW8301	GW8281	GWR6101	GWR5251								
Small Parts Machining	DCGT0702005R/L-UF	0.1-1	0-0.1												○	●	●	○						
	DCGT070201R/L-UF	0.1-1.5	0.05-0.15												○	●	●	○						
	DCGT070202R/L-UF	0.2-2	0.05-0.2												○	●	●	○						
	DCGT11T301R/F-UF	0.1-1.5	0.05-0.15												○	●	●	○						
	DCGT11T302R/F-UF	0.2-2	0.05-0.2												○	●	●	○						

Note: ●Recommended grade ready to stock



## Positive Inserts

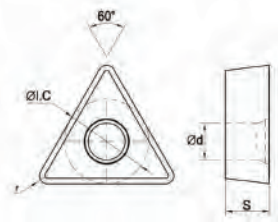

Length	Size(mm)			
	IC	S	d	r
11	6.35	3.18	2.8	0.1-0.2

60° TCGT With Hole

Shape	Type	ap (mm)	f (mm/rev)	Grade													
				CVD						PVD							
				GW0203	GW0403	GW1153	GW2134	GW2234	GW2354	GW6051	GW8201	GW6251	GW8301	GW8281	GWR6101	GWR5251	
 Small Parts Machining	TCGT110301R/L-UF	0.1-1.5	0.05-0.15							○	●	●	○				
	TCGT110302R/L-UF	0.2-2	0.05-0.2							○	●	●	○				

Note: ●Recommended grade ready to stock

## Positive Inserts

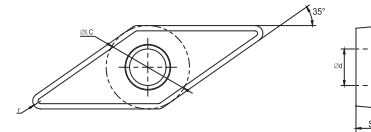

Length	Size(mm)			
	IC	S	d	r
8	4.76	2.38	2.3	0.1-0.2
11	6.35	3.18	2.8	0.1-0.2

35° VCGT With Hole

Shape	Type	ap (mm)	f (mm/rev)	Grade													
				CVD						PVD							
				GW0203	GW0403	GW1153	GW2134	GW2234	GW2354	GW6051	GW8201	GW6251	GW8301	GW8281	GWR6101	GWR5251	
 Small Parts Machining	VCGT080201R/L-UF	0.1-1.5	0.05-0.15							○	●	●	○				
	VCGT080202R/L-UF	0.2-2	0.05-0.2							○	●	●	○				
	VCGT110301R/L-UF	0.1-1.5	0.05-0.15							○	●	●	○				
	VCGT110302R/L-UF	0.2-2	0.05-0.2							○	●	●	○				

Note: ●Recommended grade ready to stock



## Negative Inserts

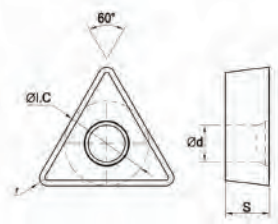

Length	Size(mm)			
	IC	S	d	r
16	9.525	4.76	3.81	0.2-0.8

60° TNGG With Hole

Shape	Type	ap (mm)	f (mm/rev)	Grade																				
				CVD						PVD														
				GW0203	GW0403	GW1153	GW2134	GW2234	GW2354	GW6051	GW8201	GW6251	GW8301	GW8281	GWR6101	GWR5251								
 Small Parts Machining	TNGG160402R/L-F	0.1-1.5	0.05-0.15							○	●	●	○											
	TNGG160404R/L-F	0.2-2	0.05-0.2							○	●	●	○											
	TNGG160408R/L-F	0.4-2.5	0.05-0.2							○	●	●	○											

Note: ●Recommended grade ready to stock

## Negative Inserts

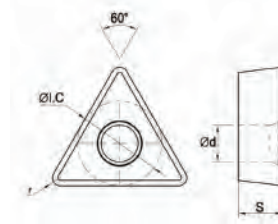

Length	Size(mm)			
	IC	S	d	r
16	9.525	4.76	3.81	0.2-0.8

60° TNGG With Hole

Shape	Type	ap (mm)	f (mm/rev)	Grade																				
				CVD						PVD														
				GW0203	GW0403	GW1153	GW2134	GW2234	GW2354	GW6051	GW8201	GW6251	GW8301	GW8281	GWR6101	GWR5251								
 Small Parts Machining	TNGG160402R/L-M	0.2-2	0.05-0.12							○	●	●	○											
	TNGG160404R/L-M	0.2-2.5	0.08-0.25							○	●	●	○											
	TNGG160408R/L-M	0.3-3	0.1-0.3							○	●	●	○											

Note: ●Recommended grade ready to stock



## Positive Inserts

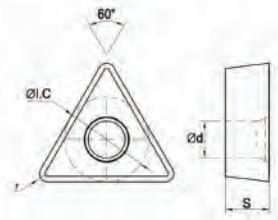

Length	Size(mm)			
	IC	S	d	r
08	4.76	2.38	2.3	0.2-0.4
09	5.56	2.38	2.8	0.2-0.4
11	6.35	3.18	3.18	0.2-0.4

60° TP GH With Hole

Shape	Type	ap (mm)	f (mm/rev)	Grade																			
				CVD						PVD													
				GW0203	GW0403	GW1153	GW2134	GW2234	GW2354	GW6051	GW8201	GW6251	GW8301	GW8281	GWR6101	GWR5251							
Small Parts Machining	TPGH080202R/L	0.2-1	0.02-0.1							○	●	●	○										
	TPGH080204R/L	0.4-1.5	0.05-0.1							○	●	●	○										
	TPGH090202R/L	0.2-1	0.02-0.1							○	●	●	○										
	TPGH090204R/L	0.4-1.5	0.05-0.1							○	●	●	○										
	TPGH110302R/L	0.2-1.5	0.02-0.15							○	●	●	○										
	TPGH110304R/L	0.4-1.5	0.05-0.15							○	●	●	○										

Note: ●Recommended grade ready to stock

## Semi-finishing for Heat Resistant Alloy

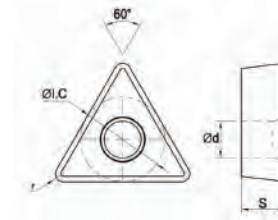

Length	Size(mm)			
	IC	S	d	RE
09	9.525	3.97	4.15	0.4
12	12.7	4.76	5.16	0.8

80° CCMT With Hole

Shape	Type	ap (mm)	f (mm/rev)	Grade																		
				CVD				PVD														
				GW1153	GW2134	GW2234	GW2354	GW0251	GW5251	GW8251	GW8241	GW8281	GW6051	GWR5101	GWR6101	GWR5251						
Semi-finishing	CCMT09T304-DM	0.3-2.2	0.05-0.15											○			○	○	●		●	
	CCMT120408-DM	0.7-3.2	0.1-0.30											○			○	○	●		●	

Note: ●Recommended grade ready to stock







## Train Wheel Turning Inserts

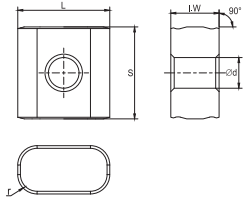

Length	Size(mm)				
	L	I.W	S	d	r
19	19.05	10	19.05	6.35	4

## Train Wheel Turning Inserts

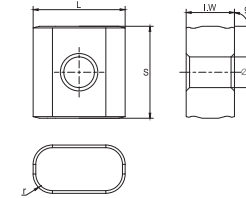

Length	Size(mm)				
	L	I.W	S	d	r
19	19.05	10	19.05	6.35	4

Shape	Type	ap (mm)	f (mm/rev)	Grade																					
				CVD						PVD															
				GW0203	GW0403	GW1153	GW2134	GW2234	GW2354	GW0251	GW5251	GW8251	GW8241	GW8281	GWR6101	GWR5251									
 Train Wheel Trimming	175.32-191940-22	2.00-5.00	0.20-0.60				●	○																	

Note: ●Recommended grade ready to stock

Shape	Type	ap (mm)	f (mm/rev)	Grade																					
				CVD						PVD															
				GW0203	GW0403	GW1153	GW2134	GW2234	GW2354	GW0251	GW5251	GW8251	GW8241	GW8281	GWR6101	GWR5251									
 Train Wheel Trimming	175.32-191940-24	2.00-5.00	0.20-0.60				●	○																	

Note: ●Recommended grade ready to stock



## Train Wheel Turning Inserts

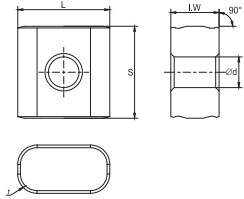

Length	Size(mm)				
	L	I.W	S	d	r
19	19.05	10	19.05	6.35	4

Shape	Type	ap (mm)	f (mm/rev)	Grade																			
				CVD						PVD													
				GW0203	GW0403	GW1153	GW2134	GW2234	GW2354	GW0251	GW5251	GW8251	GW8241	GW8281	GWR6101	GWR5251							
 Train Wheel Trimming	175.32-191940-28	2.00-5.00	0.20-0.60				●	○															

Note: ●Recommended grade ready to stock

## Parting Grooving Tools

GREWIN&COWEE  
CUTTING TOOLS





## Parting and Grooving Inserts

### Naming Rules

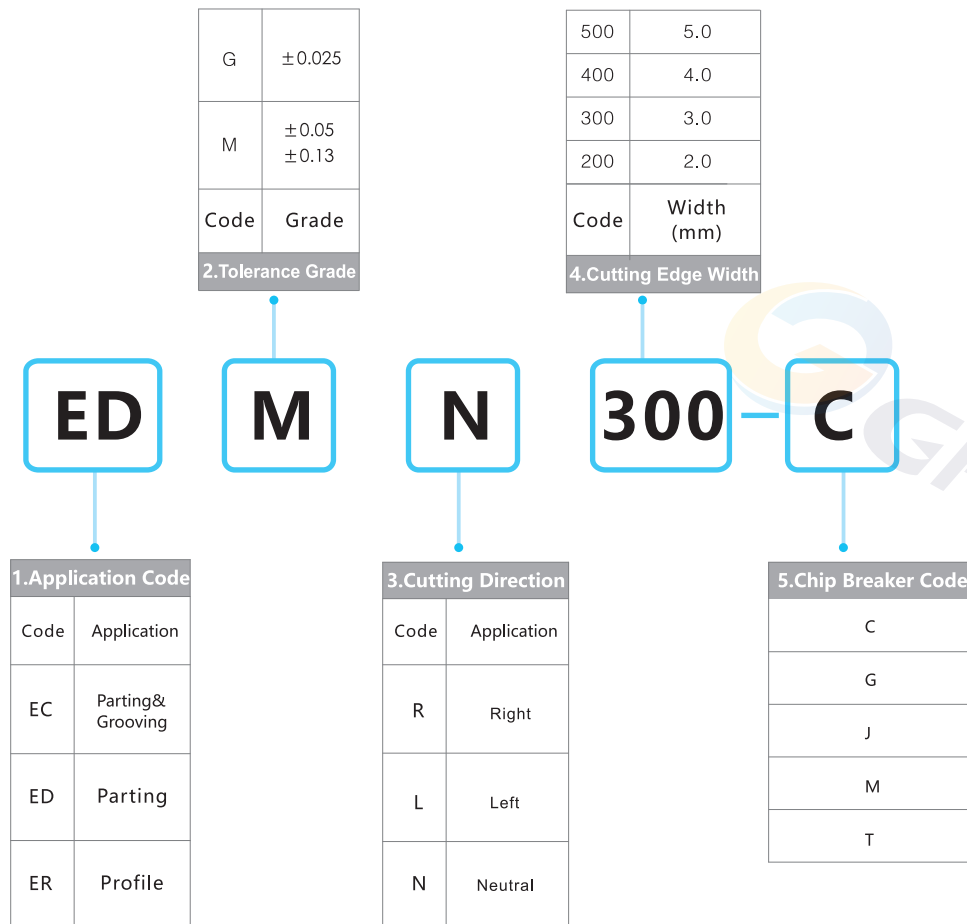

## Parting and Grooving Inserts

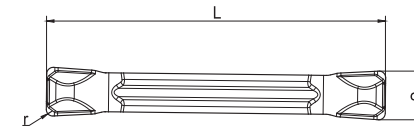

Width	Size (mm)		
	S	r±0.1	L
200	2.0	0.2	20
300	3.0	0.4	20
400	4.0	0.4	20
500	5.0	0.4	25

Shape	Type	f (mm/rev)	Grade													
			CVD					PVD								
			GW0203	GW0403	GW1153	GW2134	GW2234	GW2354	GW0251	GW5251	GW8251	GW8241	GW8281	GWR6101	GWR5251	
	EDMN200-C	0.05-0.18					●		○	●	●					
	EDMN300-C	0.07-0.25					●		○	●	●					
	EDMN400-C	0.08-0.30					●		○	●	●					
	EDMN500-C	0.09-0.35					●		○	●	●					

Note: ● Recommended grade ready to stock



## Parting and Grooving Inserts

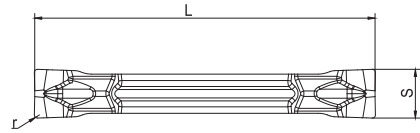

Width	Size(mm)		
	S	r±0.1	L
200	2.0	0.2	20
300	3.0	0.4	20
400	4.0	0.4	20
500	5.0	0.4	25

Shape	Type	f (mm/rev)	Grade													
			CVD						PVD							
			GW0203	GW0403	GW1153	GW2134	GW2234	GW2354	GW0251	GW5251	GW8251	GW8241	GW8281	GW6101	GW5251	
	EDMN200-J	0.04-0.12					●	○	●	●						
	EDMN300-J	0.04-0.16					●	○	●	●						
	EDMN400-J	0.05-0.18					●	○	●	●						
	EDMN500-J	0.05-0.20					●	○	●	●						

Note: ●Recommended grade ready to stock

## Parting and Grooving Inserts

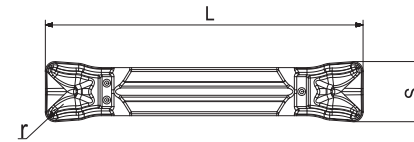

Width	Size(mm)		
	S	r±0.1	L
300	3.0	0.4	21.1
400	4.0	0.8	26.4
500	5.0	0.8	27.2
600	6.0	0.8	27.5

Shape	Type	f (mm/rev)	Grade													
			CVD						PVD							
			GW0203	GW0403	GW1153	GW2134	GW2234	GW2354	GW0251	GW5251	GW8251	GW8241	GW8281	GW6101	GW5251	
	ECMN300-T	0.05-0.18					●	○	●	●						
	ECMN400-T	0.07-0.25					●	○	●	●						
	ECMN500-T	0.08-0.3					●	○	●	●						
	ECMN600-T	0.09-0.35					●	○	●	●						

Note: ●Recommended grade ready to stock



## Parting and Grooving Inserts

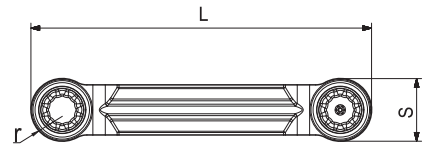

Width	Size(mm)		
	S	r±0.1	L
300	3.0	1.5	21.1
400	4.0	2	26.4
500	5.0	2.5	27.2
600	6.0	3	27.5

Shape	Type	f (mm/rev)	Grade														
			CVD						PVD								
			GW0203	GW0403	GW1153	GW2134	GW2234	GW2354	GW0251	GW5251	GW8251	GW8241	GW8281	GWR6101	GWR5251		
	ERMN300-T	0.05-0.18					●	○	●	●							
	ERMN400-T	0.07-0.25					●	○	●	●							
	ERMN500-T	0.08-0.3					●	○	●	●							
	ERMN600-T	0.09-0.35					●	○	●	●							

Note: ●Recommended grade ready to stock

## Parting and Grooving Inserts

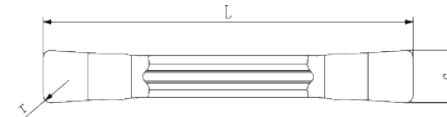

Width	Size(mm)		
	S	r±0.1	L
200	2.0	0.2	21
300	3.0	0.4	21
400	4.0	0.4	21
500	5.0	0.4	26

Shape	Type	f (mm/rev)	Grade														
			CVD						PVD								
			GW0203	GW0403	GW1153	GW2134	GW2234	GW2354	GW0251	GW5251	GW8251	GW8241	GW8281	GWR6101	GWR5251		
	MGGN200-GL	0.05-0.18					●	○	●	●							
	MGGN300-GL	0.07-0.25					●	○	●	●							
	MGGN400-GL	0.08-0.3					●	○	●	●							
	MGGN500-GL	0.09-0.35					●	○	●	●							

Note: ●Recommended grade ready to stock



## Parting and Grooving Inserts



Width	Size(mm)		
	S	r±0.1	L
200	2.0	1.0	16.0
300	3.0	1.5	21.0
400	4.0	2.0	21.0
500	5.0	2.5	26.0
600	6.0	3.0	26.0
800	8.0	4.0	31.0

Shape	Type	f (mm/rev)	Grade											
			CVD						PVD					
			GW0203	GW0403	GW1153	GW2134	GW2234	GW2354	GW0251	GW5251	GW8251	GW8241	GW8281	GWR6101
 <span style="color: red; font-weight: bold;">NEW</span>	ERMN200-M	0.05-0.15					●	○	●	●				
	ERMN300-M	0.08-0.18					●	○	●	●				
	ERMN400-M	0.10-0.20					●	○	●	●				
	ERMN500-M	0.12-0.23					●	○	●	●				
	ERMN600-M	0.15-0.27												
	ERMN800-M	0.18-0.35												

Note: ●Recommended grade ready to stock

## Grinded Grooving Inserts NEW

### Naming Rule

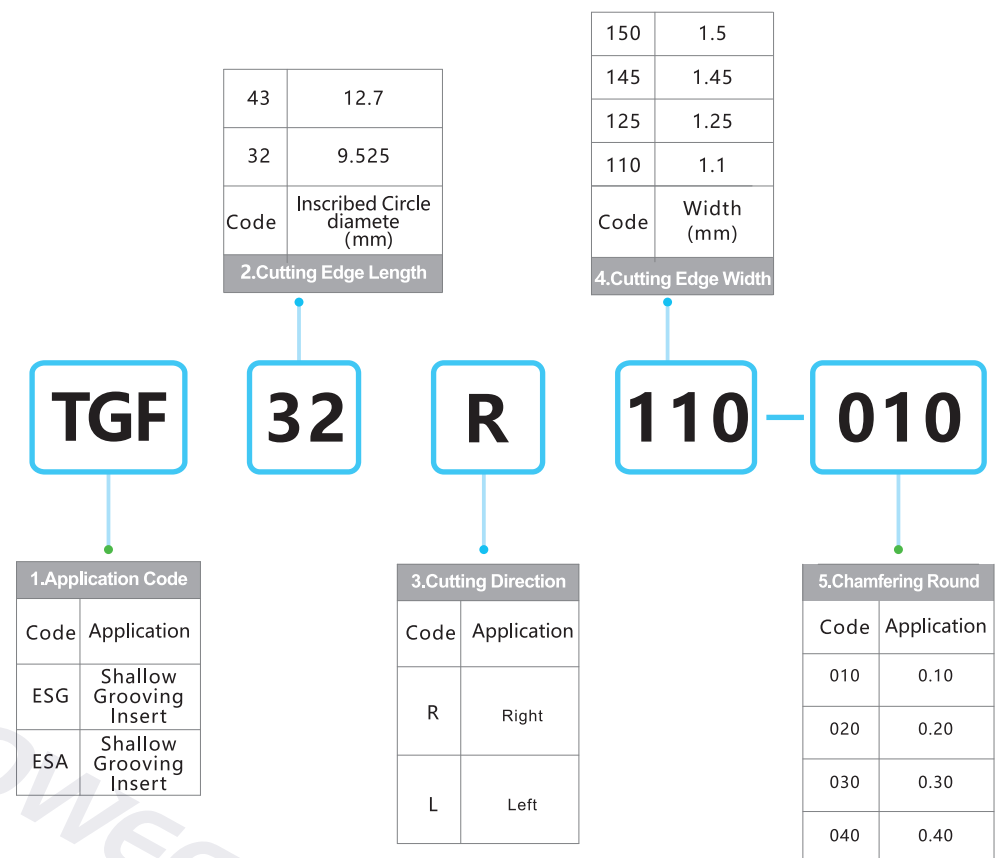



## Shallow Grooving Inserts

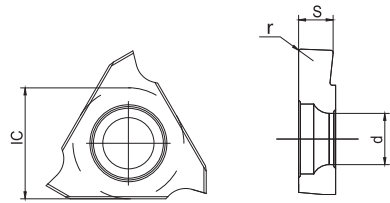

Width	Size(mm)			
	IC	S	d	r
110	9.525	1.10	4.4	0.1
125	9.525	1.25	4.4	0.1
145	9.525	1.45	4.4	0.1
150	9.525	1.50	4.4	0.1
175	9.525	1.75	4.4	0.1
185	9.525	1.85	4.4	0.1
200	9.525	2.00	4.4	0.1
250	9.525	2.50	4.4	0.1
300	9.525	3.00	4.4	0.1

Shape	Type	ap (max/mm)	Grade																
			CVD						PVD										
			GW0203	GW0403	GW1153	GW2134	GW2234	GW2354	GW6051	GW8201	GW6251	GW8301	GW8281	GWR6101	GWR5251				
	TGF32R/L033-005	0.80							○	●	●	○							
	TGF32R/L050-005	1.20							○	●	●	○							
	TGF32R/L075-010	2.00							○	●	●	○							
	TGF32R/L095-010	2.00							○	●	●	○							
	TGF32R/L100-010	2.00							○	●	●	○							
	TGF32R/L110-010	2.00							○	●	●	○							
	TGF32R/L125-010	2.00							○	●	●	○							
	TGF32R/L145-010	2.50							○	●	●	○							
	TGF32R/L150-010	2.50							○	●	●	○							
	TGF32R/L175-010	2.50							○	●	●	○							
	TGF32R/L185-010	2.50							○	●	●	○							
	TGF32R/L200-010	2.50							○	●	●	○							
	TGF32R/L250-010	2.50							○	●	●	○							
TGF32R/L300-010	2.50							○	●	●	○								

Note: ●Recommended grade ready to stock

## Shallow Grooving Inserts

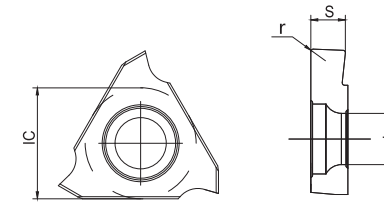

Width	Size(mm)			
	IC	S	d	r
125	12.7	1.25	4.4	0.1
125	12.7	1.25	4.4	0.2
150	12.7	1.50	4.4	0.1
150	12.7	1.50	4.4	0.2
200	12.7	2.00	4.4	0.1
200	12.7	2.50	4.4	0.2
250	12.7	2.50	4.4	0.1
250	12.7	2.50	4.4	0.2
300	12.7	3.00	4.4	0.1
300	12.7	3.00	4.4	0.2

Shape	Type	ap (max/mm)	Grade																
			CVD						PVD										
			GW0203	GW0403	GW1153	GW2134	GW2234	GW2354	GW6051	GW8201	GW6251	GW8301	GW8281	GWR6101	GWR5251				
	GBA43R/L125-010	2.00							○	●	●	○							
	GBA43R/L125-020								○	●	●	○							
	GBA43R/L150-010	3.50							○	●	●	○							
	GBA43R/L150-020								○	●	●	○							
	GBA43R/L200-010									○	●	●	○						
	GBA43R/L200-020									○	●	●	○						
	GBA43R/L250-010	4.00							○	●	●	○							
	GBA43R/L250-020								○	●	●	○							
	GBA43R/L300-010									○	●	●	○						
	GBA43R/L300-020									○	●	●	○						

Note: ●Recommended grade ready to stock

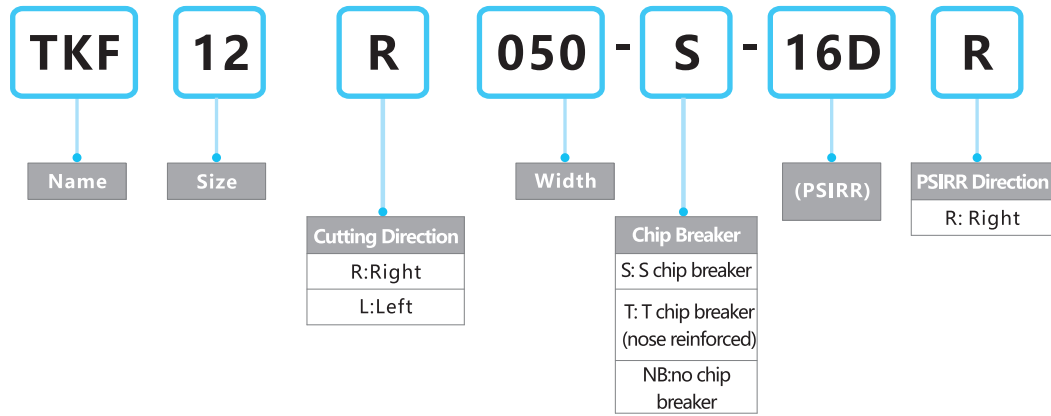

## Special Parting Inserts

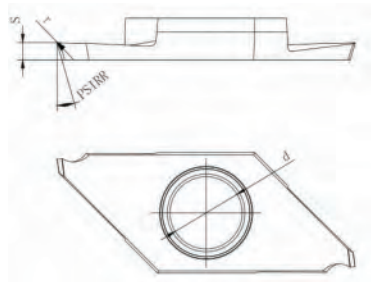

Width	Size(mm)			
	PSIRR	S	d	r
50	16°	0.50	5.2	0.03
70		0.70	5.2	0.03
100		1.00	5.2	0.03
125		1.25	5.2	0.03
150		1.50	5.2	0.03
200	2.00	5.2	0.03	
50	0°	0.50	5.2	0.03
70		0.70	5.2	0.03
100		1.00	5.2	0.03
125		1.25	5.2	0.03
150		1.50	5.2	0.03
200	2.00	5.2	0.03	
100	16°	1.00	5.2	0.08
150		1.50	5.2	0.08
200		2.00	5.2	0.08
100	0°	1.00	5.2	0.08
150		1.50	5.2	0.08
200		2.00	5.2	0.08

Shape	Type	ap (max/mm)	Grade													
			CVD					PVD								
			GW0203	GW0403	GW1153	GW2134	GW2234	GW2354	GW6051	GW8201	GW6251	GW8301	GW8281	GWR6101	GWR5251	
	TKF12R/L050-S-16DR	5.00									○	●	●	○		
	TKF12R/L070-S-16DR	8.00									○	●	●	○		
	TKF12R/L100-S-16DR	12.00									○	●	●	○		
	TKF12R/L125-S-16DR	12.00									○	●	●	○		
	TKF12R/L150-S-16DR										○	●	●	○		
	TKF12R/L200-S-16DR										○	●	●	○		
	TKF12R/L050-S	5.00									○	●	●	○		
	TKF12R/L070-S	8.00									○	●	●	○		
	TKF12R/L100-S	12.00									○	●	●	○		
	TKF12R/L125-S										○	●	●	○		
	TKF12R/L150-S										○	●	●	○		
	TKF12R/L200-S										○	●	●	○		
	TKF12R/L100-T-16DR										○	●	●	○		
	TKF12R/L150-T-16DR										○	●	●	○		
	TKF12R/L200-T-16DR									○	●	●	○			
TKF12R/L100-T									○	●	●	○				
TKF12R/L150-T									○	●	●	○				
TKF12R/L200-T									○	●	●	○				

Note: ● Recommended grade ready to stock



## Special Parting Inserts

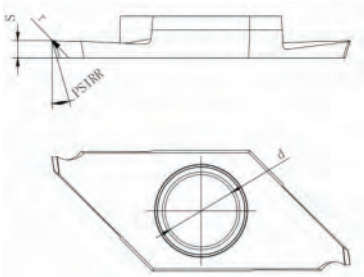

Width	Size(mm)			
	PSIRR	S	d	r
150	16°	1.50	5.2	0.05
200		2.00	5.2	0.05
150		1.50	5.2	0.05
200		2.00	5.2	0.05
150		1.50	5.2	0.08
200		2.00	5.2	0.08
150	0°	1.50	5.2	0.08
200		2.00	5.2	0.08

Shape	Type	ap (max/mm)	Grade													
			CVD						PVD							
			GW0203	GW0403	GW1153	GW2134	GW2234	GW2354	GW6051	GW8201	GW6251	GW8301	GW8281	GWR6101	GWR5251	
	TKF16R/L150-S-16DR	16.00							○	●	●	○				
	TKF16R/L200-S-16DR								○	●	●	○				
	TKF16R/L150-S								○	●	●	○				
	TKF16R/L150-S								○	●	●	○				
	TKF16R/L150-T-16DR								○	●	●	○				
	TKF16R/L200-T-16DR								○	●	●	○				
	TKF16R/L150-T								○	●	●	○				
	TKF16R/L200-T								○	●	●	○				

Note: ● Recommended grade ready to stock

## Threading Inserts

### Naming Rules

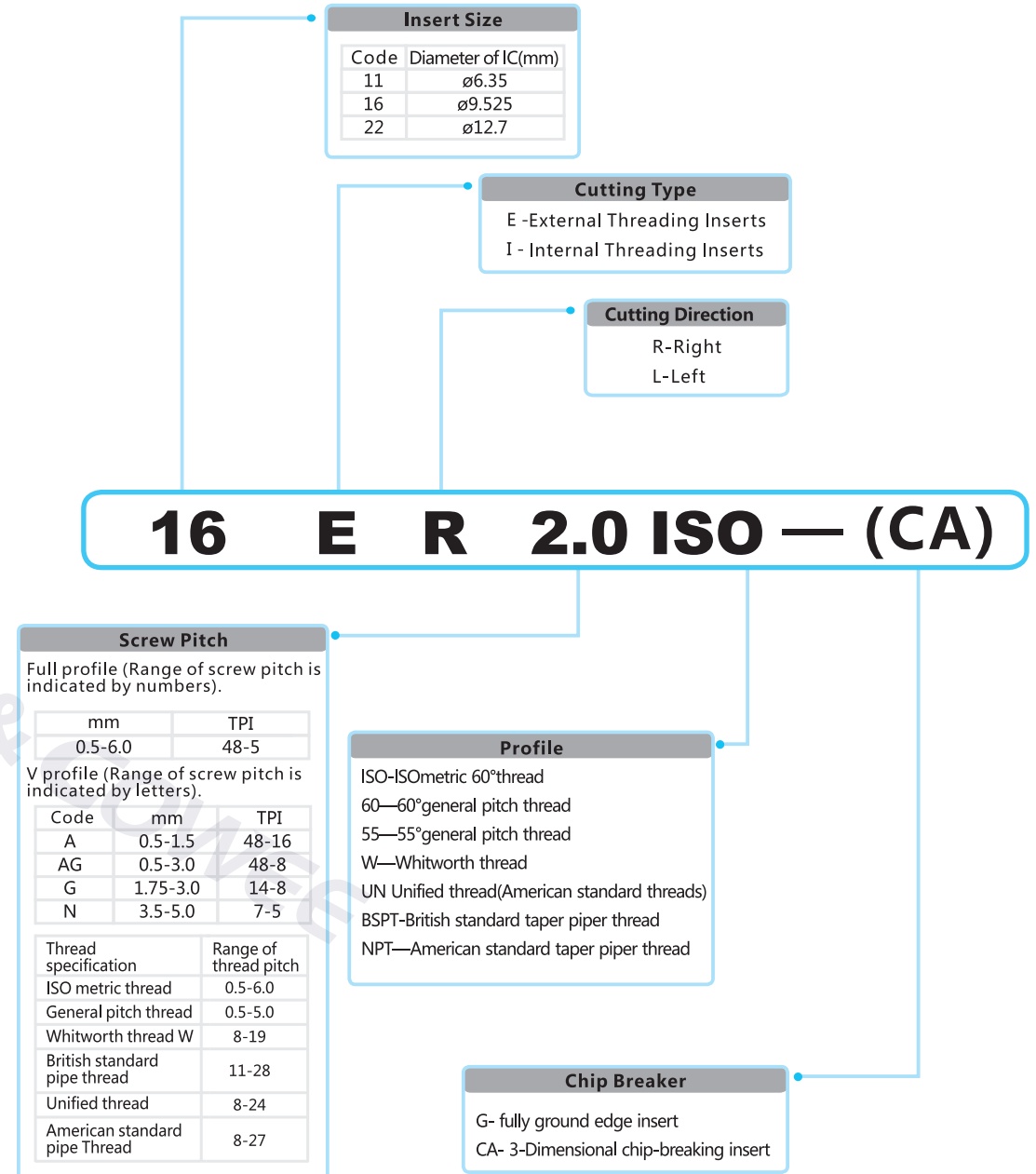



## ISO Metric Thread

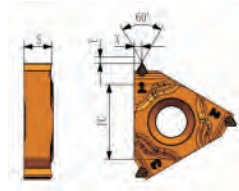
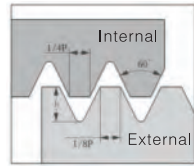

Standard:R262(DIN 13) Tolerance Class:6g/6H

★With End

Shape	Type	Range of Thread Pitch		Insert Dimestions(mm)				Coating	
		mm	pitch/inch	IC	S	X	Y	GW8251	GW5201
	16ER1.00ISO-CA	1		9.525	3.52	0.7	0.6	●	○
	16ER1.25ISO-CA	1.25		9.525	3.52	0.9	0.7	●	○
	16ER1.50ISO-CA	1.5		9.525	3.52	1	0.8	●	○
	16ER1.75ISO-CA	1.75		9.525	3.52	1.1	0.9	●	○
	16ER2.00ISO-CA	2		9.525	3.52	1.2	0.9	●	○
	16ER2.50ISO-CA	2.5		9.525	3.52	1.5	1.1	●	○
	16ER3.00ISO-CA	3		9.525	4.65	1.7	1.2	●	○
	16IR1.00ISO-CA	1		9.525	3.52	0.7	0.6	●	○
	16IR1.25ISO-CA	1.25		9.525	3.52	0.8	0.6	●	○
	16IR1.50ISO-CA	1.5		9.525	3.52	0.9	0.7	●	○
	16IR1.75ISO-CA	1.75		9.525	3.52	1	0.8	●	○
	16IR2.00ISO-CA	2		9.525	3.52	1.1	0.8	●	○
	16IR2.50ISO-CA	2.5		9.525	3.52	1.4	1	●	○
	16IR3.00ISO-CA	3		9.525	4.65	1.5	1.1	●	○

Note: ●Recommended grade ready to stock

## ISO Metric Thread

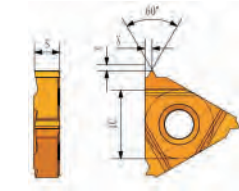
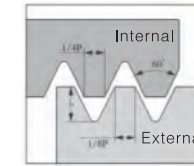

Standard:R262(DIN 13) Tolerance Class:6g/6H

★With End

Shape	Type	Range of Thread Pitch		Insert Dimestions(mm)				Coating	
		mm	pitch/inch	IC	S	X	Y	GW8251	GW5201
	16ER1.00ISO-G	1		9.525	3.52	0.7	0.6	●	○
	16ER1.25ISO-G	1.25		9.525	3.52	0.9	0.7	●	○
	16ER1.50ISO-G	1.5		9.525	3.52	1	0.8	●	○
	16ER1.75ISO-G	1.75		9.525	3.52	1.1	0.9	●	○
	16ER2.00ISO-G	2		9.525	3.52	1.2	0.9	●	○
	16ER2.50ISO-G	2.5		9.525	3.52	1.5	1.1	●	○
	16ER3.00ISO-G	3		9.525	4.65	1.7	1.2	●	○
	22ER3.50ISO-G	3.5		12.7	4.65	2.3	1.6	●	○
	22ER4.00ISO-G	4		12.7	4.65	2.3	1.6	●	○
	22ER4.50ISO-G	4.5		12.7	4.65	2.4	1.7	●	○
	22ER5.00ISO-G	5		12.7	4.65	2.5	1.7	●	○
	11IR1.00ISO-G	1		6.35	3.05	0.7	0.6	●	○
	11IR1.25ISO-G	1.25		6.35	3.05	0.9	0.8	●	○
	11IR1.50ISO-G	1.5		6.35	3.05	1	0.8	●	○
	11IR1.75ISO-G	1.75		6.35	3.05	1.1	0.9	●	○
11IR2.00ISO-G	2		6.35	3.05	1.1	0.9	●	○	
	16IR1.00ISO-G	1		9.525	3.52	0.7	0.6	●	○
	16IR1.25ISO-G	1.25		9.525	3.52	0.8	0.6	●	○
	16IR1.50ISO-G	1.5		9.525	3.52	0.9	0.7	●	○
	16IR1.75ISO-G	1.75		9.525	3.52	1	0.8	●	○
	16IR2.00ISO-G	2		9.525	3.52	1.1	0.8	●	○
	16IR2.50ISO-G	2.5		9.525	3.52	1.4	1	●	○
	16IR3.00ISO-G	3		9.525	4.65	1.5	1.1	●	○
	22IR3.50ISO-G	3.5		12.7	4.65	2.3	1.6	●	○
	22IR4.00ISO-G	4		12.7	4.65	2.3	1.6	●	○
	22IR4.50ISO-G	4.5		12.7	4.65	2.4	1.7	●	○
22IR5.00ISO-G	5		12.7	4.65	2.5	1.7	●	○	

Note: ●Recommended grade ready to stock



## 55°/60° General Pitch Thread

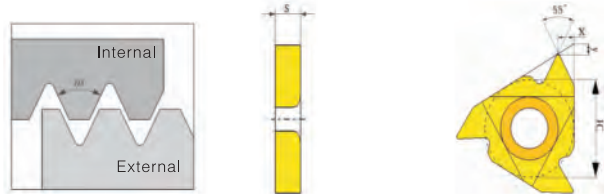

★Without End

Shape	Type	Range of Thread Pitch		Insert Dimensions(mm)				Coating	
		mm	pitch/inch	IC	S	X	Y	GW8251	GW5201
	16ERA55	0.5–1.5	48–16	9.525	3.52	0.9	0.8	●	○
	16ERAG55	0.5–3.0	48–8	9.525	3.52	1.7	1.2	●	○
	16ERG55	1.75–3.0	14–8	9.525	3.52	1.7	1.2	●	○
	22ERN55	3.5–5.0	7–5	12.7	4.65	2.5	1.7	●	○
	11IRA55	0.5–1.5	48–16	6.35	3.52	0.9	0.8	●	○
	16IRA55	0.5–1.5	48–16	9.525	3.52	0.9	0.8	●	○
	16IRAG55	0.5–3.0	48–8	9.525	3.52	1.7	1.2	●	○
	16IRG55	1.75–3.0	14–8	9.525	3.52	1.7	1.2	●	○
	22IRN55	3.5–5.0	7–5	12.7	4.65	2.5	1.7	●	○

Shape	Type	Range of Thread Pitch		Insert Dimensions(mm)				Coating	
		mm	pitch/inch	IC	S	X	Y	GW8251	GW5201
	16ERA60	0.5–1.5	48–16	9.525	3.52	0.9	0.8	●	○
	16ERAG60	0.5–3.0	48–8	9.525	3.52	1.7	1.2	●	○
	16ERG60	1.75–3.0	14–8	9.525	3.52	1.7	1.2	●	○
	22ERN60	3.5–5.0	7–5	12.7	4.65	2.5	1.7	●	○
	11IRA60	0.5–1.5	48–16	6.35	3.52	0.9	0.8	●	○
	16IRA60	0.5–1.5	48–16	9.525	3.52	0.9	0.8	●	○
	16IRAG60	0.5–3.0	48–8	9.525	3.52	1.7	1.2	●	○
	16IRG60	1.75–3.0	14–8	9.525	3.52	1.7	1.2	●	○
	22IRN60	3.5–5.0	7–5	12.7	4.65	2.5	1.7	●	○

Note: ●Recommended grade ready to stock

## Whitworth Thread

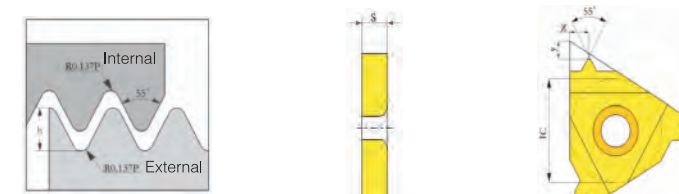

Standard: B.S.84: 1956, DIN259, ISO288/1:1982  
Tolerance class: Medium class A

★With End

Shape	Type	Range of Thread Pitch		Insert Dimensions(mm)				Coating	
		mm	pitch/inch	IC	S	X	Y	GW8251	GW5201
	16ER8W		8	9.525	3.52	1.5	1.2	●	○
	16ER9W		9	9.525	3.52	1.7	1.2	●	○
	16ER10W		10	9.525	3.52	1.5	1.1	●	○
	16ER11W		11	9.525	3.52	1.5	1.1	●	○
	16ER12W		12	9.525	3.52	1.4	1.1	●	○
	16ER14W		14	9.525	3.52	1.2	1	●	○
	16ER16W		16	9.525	3.52	1.1	0.9	●	○
	16ER18W		18	9.525	3.52	1	0.8	●	○
	16ER19W		19	9.525	3.52	1	0.8	●	○
	16IR8W		8	9.525	3.52	1.5	1.2	●	○
	16IR9W		9	9.525	3.52	1.7	1.2	●	○
	16IR10W		10	9.525	3.52	1.5	1.1	●	○
	16IR11W		11	9.525	3.52	1.5	1.1	●	○
	16IR12W		12	9.525	3.52	1.4	1.1	●	○
	16IR14W		14	9.525	3.52	1.2	1	●	○
	16IR16W		16	9.525	3.52	1.1	0.9	●	○
	16IR18W		18	9.525	3.52	1	0.8	●	○
	16IR19W		19	9.525	3.52	1	0.8	●	○

Note: ●Recommended grade ready to stock



## British Standard Taper Piper Thread

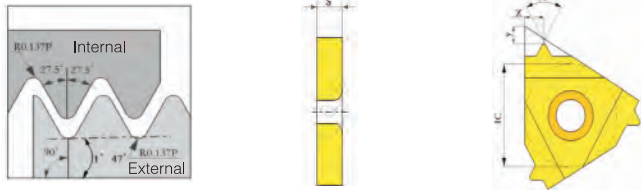

Standard: B.S.21 : 1985  
Tolerance class: BSPT

★With End

Shape	Type	Range of Thread Pitch		Insert Dimensions(mm)				Coating	
		mm	pitch/inch	IC	S	X	Y	GW8251	GW5201
	16ER11BSPT		11	9.525	3.52	1.5	1.1	●	○
	16ER14BSPT		14	9.525	3.52	1.2	1	●	○
	16ER19BSPT		19	9.525	3.52	0.9	0.8	●	○
	16ER28BSPT		28	9.525	3.52	0.6	0.6	●	○
	16IR11BSPT		11	9.525	3.52	1.5	1.1	●	○
	16IR14BSPT		14	9.525	3.52	1.2	1	●	○
	16IR19BSPT		19	9.525	3.52	0.9	0.8	●	○
	16IR28BSPT		28	9.525	3.52	0.6	0.6	●	○

Note: ●Recommended grade ready to stock

## Unified Thread

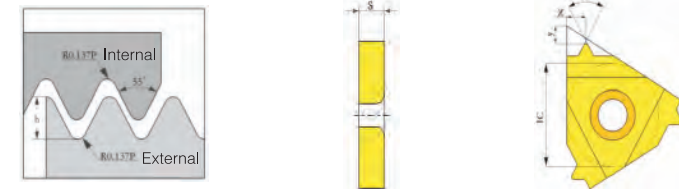

Standard: ANSI B1.1:74  
Tolerance class: 2A/2B

★With End

Shape	Type	Range of Thread Pitch		Insert Dimensions(mm)				Coating	
		mm	pitch/inch	IC	S	X	Y	GW8251	GW5201
	16ER8UN		8	9.525	3.52	1.6	1.2	●	○
	16ER10UN		10	9.525	3.52	1.5	1.1	●	○
	16ER12UN		12	9.525	3.52	1.4	1.1	●	○
	16ER14UN		14	9.525	3.52	1.2	1	●	○
	16ER16UN		16	9.525	3.52	1.1	0.9	●	○
	16ER18UN		18	9.525	3.52	1	0.8	●	○
	16ER20UN		20	9.525	3.52	0.9	0.8	●	○
	16ER24UN		24	9.525	3.52	0.8	0.7	●	○
	16IR8UN		8	9.525	3.52	1.5	1.1	●	○
	16IR10UN		10	9.525	3.52	1.5	1.1	●	○
	16IR12UN		12	9.525	3.52	1.4	1.1	●	○
	16IR14UN		14	9.525	3.52	1.2	0.9	●	○
	16IR16UN		16	9.525	3.52	1.1	0.9	●	○
	16IR18UN		18	9.525	3.52	1	0.8	●	○
	16IR20UN		20	9.525	3.52	0.9	0.8	●	○
	16IR24UN		24	9.525	3.52	0.8	0.7	●	○

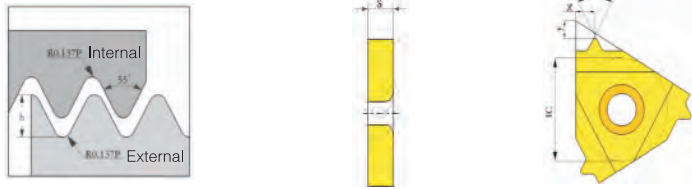

Note: ●Recommended grade ready to stock

## American Standard Taper Piper Thread



Standard: USAS B.21:1968  
Tolerance class: NPT

★With End

Shape	Type	Range of Thread Pitch		Insert Dimestions(mm)				Coating	
		mm	pitch/inch	IC	S	X	Y	GW8251	GW5201
	16ER8NPT		8	9.525	3.52	1.8	1.3	●	○
	16ER11.5NPT		11.5	9.525	3.52	1.5	1.1	●	○
	16ER14NPT		14	9.525	3.52	1.2	0.9	●	○
	16ER18NPT		18	9.525	3.52	1	0.8	●	○
	16ER27NPT		27	9.525	3.52	0.8	0.7	●	○
	16IR8NPT		8	9.525	3.52	1.8	1.3	●	○
	16IR11.5NPT		11.5	9.525	3.52	1.5	1.1	●	○
	16IR14NPT		14	9.525	3.52	1.2	0.9	●	○
	16IR18NPT		18	9.525	3.52	1	0.8	●	○
	16IR27NPT		27	9.525	3.52	0.8	0.7	●	○

Note: ●Recommended grade ready to stock

# Milling Inserts

GREWIN&COWEE  
CUTTING TOOLS





## Turbocharger

Due to fuel saving, power, environmental protection and other reasons, turbochargers are increasingly widely used, becoming an indispensable part of the internal combustion engine. Turbocharger shell is the most important part of the turbocharger, the material is mostly made of high temperature resistant alloy material, e.g. 1.4826, 1.4837, 1.4848, 1.4849 etc.

Our technical team is committed to developing new cutting tool materials, insert chip breakers and coatings. Currently, we are able to provide the perfect solution for different conditions for the machining of turbocharger housings from roughing to finishing.



Milling Inserts

Milling Insert

### Application No.1



Heptagonal face milling cutter, 14 effective cutting edges, rough milling of flange planes, excellent cost performance

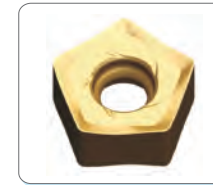

PN09 is for finish milling of turbine shell flange plane with good surface cleanliness



CN12 is for rough machining of external and internal boring of turbine casing.

### Application No.2



SN09 is for back milling of flanges.



DN15 is for internal Finish boring for turbine shell



SD09 is for internal plane machining.



### Case No.1

Workpiece material:heat-resisting steels

Workpiece:Turbine shell

Cooling type:Compressed Air

Original blade:A foreign brand

Grewin insert:ONHU050408-AF GWR0281

Cutting parameter:Vc:168m/min fz:0.07mm/z ap:2.3mm

Conclusion: Our inserts cutting light and fast, low cutting force, even wear on the rear surface, compared with a foreign brand processing life of 15 pieces / edge, our products are more cost-effective.

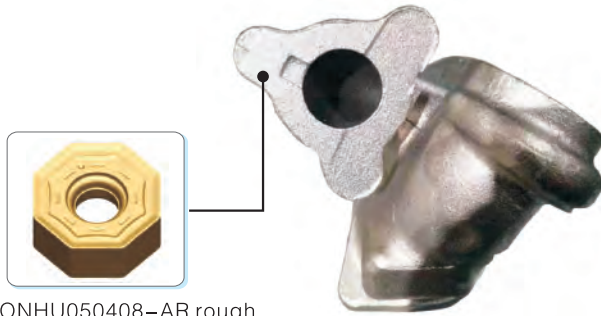

ONHU050408-AR rough milling of turbine shell plane.

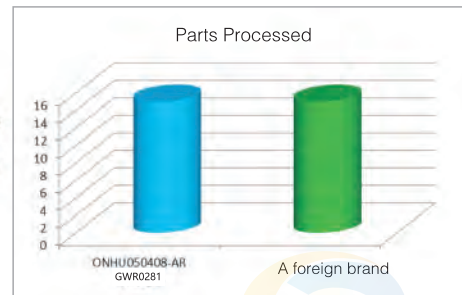

### Case No.2

Workpiece material:heat-resisting steels 1.4837

Workpiece:Turbine shell

Cooling type:Cooling Liquid

Original blade:A foreign brand

Grewin insert:XNGU0705ANN-GR GWR0281

Cutting parameter:Vc:261.2m/min fz:0.08mm/z ap:1.5~2mm

Conclusion: Our inserts processed 32 pieces, a foreign brand processed 30 pieces, the tool life increased by 7% with good cost performance.

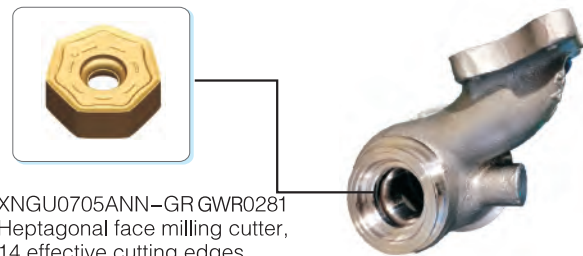

XNGU0705ANN-GR GWR0281 Heptagonal face milling cutter, 14 effective cutting edges, rough milling of flange planes, excellent cost performance

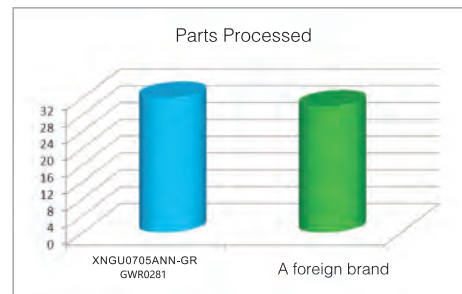

### Case No.3

Workpiece material:heat-resisting steels 1.4837

Workpiece:Turbine shell

Cooling type:Compressed Air

Original blade:A foreign brand

Grewin insert:CNMG120412-DM GWR0251

Cutting parameter:Boring:Vc:111m/min fz:0.18 mm/rev ap:1.75mm

End face:Vc:120m/min fz:0.15mm/rev ap:1.3mm

Service life:3 pieces/edge

Conclusion: Used for turbine shell boring and end face rough machining, and end face for intermittent processing, our inserts can process 3 pieces, a foreign brand processed 2 pieces, and successfully replaced

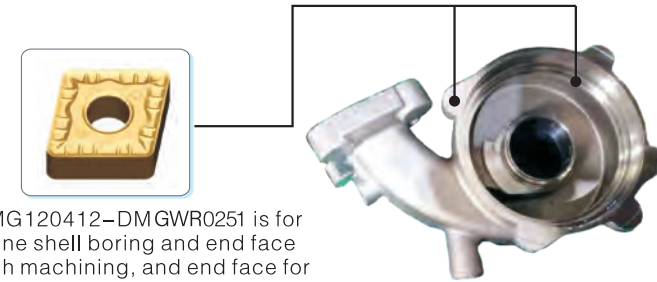

CNMG120412-DM GWR0251 is for turbine shell boring and end face rough machining, and end face for intermittent processing

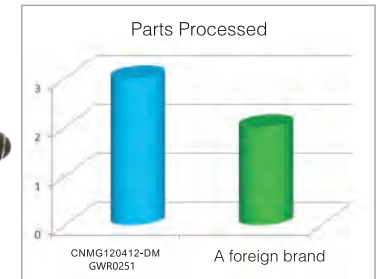

### Case No.4

Workpiece material:heat-resisting steels 1.4837

Workpiece: Turbine shell

Cooling type:Cooling Liquid

Original blade:A foreign brand

Grewin insert:DNMG150404-DM GWR0251

Cutting parameter: Vc: 130m/min fz=0.1 mm/rev ap=0.2mm

Service life:5 pieces/edge

Conclusion: Used in the turbine casing boring and end face finishing, our inserts processed 5 pieces, a foreign brand processed 5 pieces, the single cost per piece of workpiece processing is low, and our insert's rear tool surface wear less than competitor's

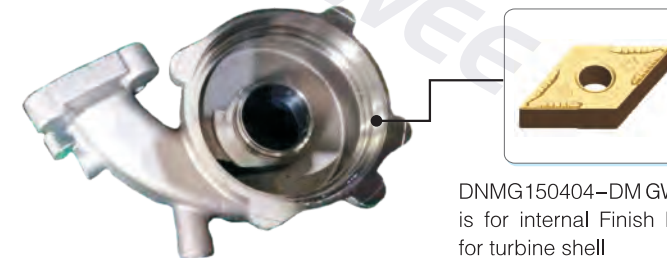

DNMG150404-DM GWR0251 is for internal Finish boring for turbine shell

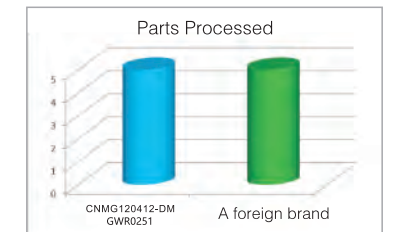



## SHARK TOOTH - Milling Insert for Turbine Blades

### 1 Steam Turbine Blade Material and Its Characteristics

Blade often use high strength, toughness, good thermal hardness of heat-resistant stainless steel, mechanical processing is difficult as follows

- Large machining allowance, in order to improve production efficiency, cutting with the highest possible cutting parameters
- High strength, high cutting force, high machining temperature, fast tool wear, easy to chipping
- Severe machining hardening, high tool groove wear

### 2 Grade Features

- Stronger bonding phase, higher resistance to plastic deformation and wear resistance, and excellent toughness
- High aluminum content gradient nano-coating for increased oxidation resistance and cutting temperature
- Smooth product surface to prevent chip tumor accumulation



### Case No.1

Workpiece material: 2Cr12NiMo1W1V  
 Workpiece: High pressure cylinder stage 12 dynamic and locking lobe  
 Cooling type: Compressed Air  
 Processing type: Rough milling of airway profiles  
 Original blade: A foreign brand  
 Grewin insert: RPMT1204M0 GWR0281  
 Cutting parameter:  $V_c: 231\text{m/min}$   $f_z: 0.38\text{mm/z}$   $a_p: 1.5\text{mm}$   
 Conclusion: Our blade life is 4 pieces/edge, that is single piece for 16 workpieces. A foreign brand blade life is 2 pieces/edge. Our processing quantity is 200% of the foreign brand, and the cost is significantly reduced.

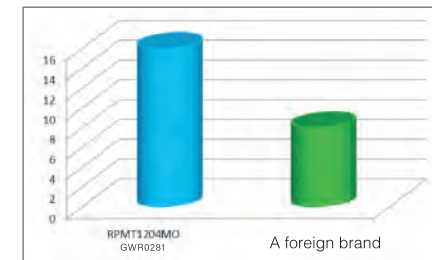

### Case No.2

Workpiece material: 10Cr11Co3W3NiMoVNB  
 Workpiece: High pressure level 5  
 Cooling type: Compressed Air  
 Processing type: Rough milling of airway profiles  
 Original blade: A foreign brand  
 Grewin insert: RPMT1204M0 GWR0281  
 Cutting parameter:  $V_c: 221\text{m/min}$   $f_z: 0.51\text{mm/z}$   $a_p: 1.5\text{mm}$   
 Conclusion: Our blade life is 1 piece/edge, that is single piece for 4 workpieces. A foreign brand blade life is 1 piece/edge. Both are forced to change the blade after processing 1 piece. Our blade wear is smaller and the cost is reduced.

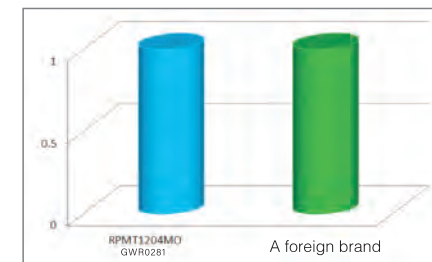



## HIGH FEED - Cyclone Milling

### 1. LNMU Series

#### Feature of Chip Breaker

- Double-sided fast feed, cost-effective with 4-edges
- Optimized edge preparation for machining steel, stainless steel, cast iron and high-temperature alloys, etc.
- Inserts  $A_p$  is up to 1mm and can be used for shoulder milling, groove milling, ramp milling and small depth milling.



#### Case :

Workpiece material: Alloy Steel  
 Workpiece: Cutter grooving  
 Cooling type: Compressed Air  
 Original blade: A foreign brand  
 Grewininsert: LNMU0303ZER-GM GW0251  
 Cutting parameter:  $V_c$ :126m/min,  $f_z$ :0.3mm/z,  $a_p$ :0.8mm  
 Conclusion: Our blade processed 46 pcs edge, a foreign brand processed 33 pcs edge, tool life increased by 40% to meet customers' cost-effective needs.

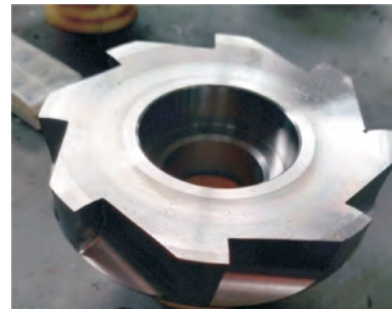
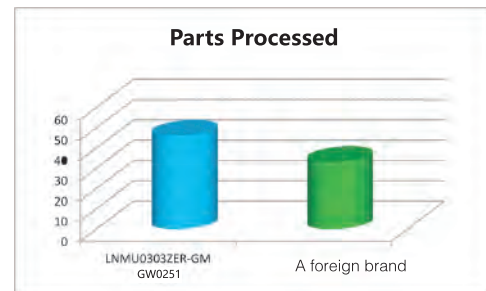

### 2. LOGU Series

#### Feature of Chip Breaker

- Double-sided with 4-edges
- Precision ground inserts for higher indexing accuracy
- Small-diameter and multi-edge for efficient machining, end mill diameter range 16-32mm



#### Case :

Workpiece material: 45# Steel  
 Workpiece: Automotive mold parts  
 Cooling type: Compressed Air  
 Original blade: A foreign brand  
 Grewininsert: LOGU030310ER-MM GW8251  
 Cutting parameter:  $V_c$ :180m/min,  $f_z$ :0.77mm/z,  $a_p$ :0.7mm  
 Conclusion: Our blade processed 3 pcs edge, a foreign brand processed 1 pcs edge, our blade efficiency increased by 4-5 times, the unit cost reduced by 5 times.

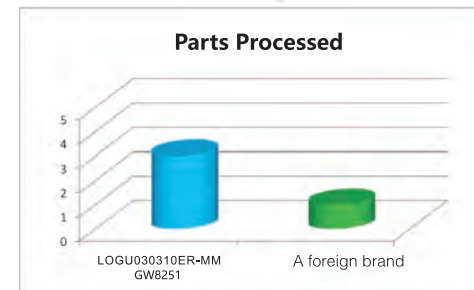



## HIGH FEED - New Application

### Replaces Traditional Round Milling Inserts

#### 3. SOMT Series

##### Feature of Chip Breaker

- Fast Feed for General Milling
- Convex cutting edge design inhibits impact during insert feed and improves the impact resistance of the insert.
- For flat surface machining, cavity machining and helical milling.

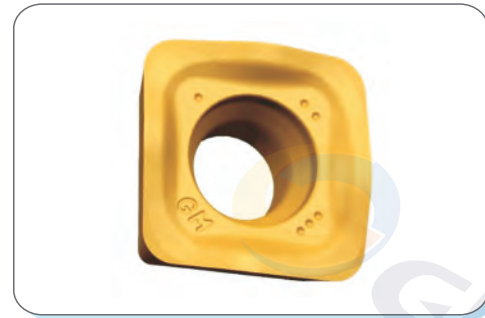

##### Case :

Workpiece material:SUS 431  
 Workpiece:Mask machine spinneret  
 Cooling type:Compressed Air  
 Original blade:A foreign brand–RPEW1003  
 Cutting parameter: Vc: 271 m/min, fz:0.91 mm/z, ap:0.3mm  
 Grewin insert:SOMT140520–GM GW0251  
 Cutting parameter: Vc: 178m/min, fz:1.23mm/z , ap:1mm  
 Conclusion: Fast feed inserts replace traditional round inserts, metal removal rate increased by 3.6 times per unit time, cutting performance increased by 300%, and tool cost reduced by 80%.

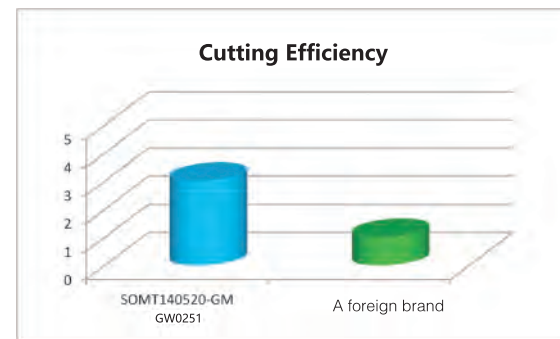

### Recommendation of Milling Grade

ISO		CVD			PVD		
K Cast Iron	01						
	10	GW0203			GW0151	GW8251	GW5251
	20						
	30		GW0403				
	40						
P Steel	01						
	10				GW0151		
	20					GW8251	GW0251
	30						
	40						
M Stainless Steel	01						
	10				GW8201		
	20					GW8241	GW8251
	30						GW8281
	40						GW5251
S Heat Resistant Alloy	01						
	10				GWR6101		
	20					GWR5251	
	30						
	40						GWR0291



## Recommendation of Inserts and Chip Breakers

































Should Milling Inserts						
	APMT-XR	APMT-GM	APMT-M2	APMT-H2	ADMT-JT	TPKT
Length	11/16	11/16	11/16	11/16	11/16	04/09
Page	B-16	B-16	B-17	B-17	B-18	B-19
Double-side Should Milling Inserts						
	ANMX	ANKT-M	LNGU-GM	WNMU-GM	XNEX-GL/GM	
Length	11/15	04/06/09/11	11	05/08	08	
Page	B-20	B-21	B-22	B-22	B-23	
Profile Milling Inserts						
	RPMW	RPMT-JM	RPMT-GM	RDKT	RPMT-XR	RPMT
Length	08/10/12	08/10/12/16	08/10/12	08/20	08/10/12	12
Page	B-24	B-24	B-25	B-26	B-27	B-28
Single-side High Feed Milling Inserts						
	EPNW-GH	LPGT-GM	SDMT-GM	SDMT-GH	SOMT-GM	SOMT-GH
Length	06	01	12/15	06/15	10	14
Page	B-29	B-29	B-30	B-30	B-31	B-31
Double-side High Feed Milling Inserts				45° Face Milling Inserts		
	LNMU-GM	LOGU-GM	BLMP-GM		SEMT-GM	SEER-GM
Length	03	03	04-11	Length	12	12/15
Page	B-32	B-32	B-33	Page	B-38	B-38







Super Alloy Titanium Alloy					
	RPHX-DF	RPHX-DM	APMT-DF	SDMT-DM	LNMU-MS
Length	10/12	10/12	11/16	06/09	03
Page	B-35	B-35	B-36	B-36	B-37
Double-side Cost-effective Face Milling Inserts					
	SNMU-GM	SNMX-GM	SNGX-GF	PNCU-GM	HNMG-R
Length	13	12/16	09	09	09
Page	B-39	B-40	B-40	B-41	B-42
Double-side Cost-effective Face Milling Inserts					
	HNMG-M	XNMU-MM	XNMU-GR	ONHU-AR	ONHU-AF
Length	09	07	07/09	05	05
Page	B-42	B-43	B-43	B-44	B-44
Double-side Cost-effective Face Milling Inserts		Helix Milling Inserts			
	ONMU-GM		APKT-PM	SP-KM	SP-PM
Length	09	Length	15	12	12
Page	B-45	Page	B-46	B-46	B-46



Helical Milling Inserts			
	CNHX	LNKT	LNKX
Length	16	16	12
Page	B-47	B-47	B-48



## Milling Insert Code Key

 A	 B	 C	B	Y	N		N	N	N	
 D	 E	 H	H	Y	Single		R	N	Single	
 K	 L	 M	C	Y	N		F	N	Double	
 O	 P	 R	J	Y	Double		A	Y	N	
 S	 T	 T	W	Y	N		M	Y	Single	
 V	 W	Others	T	Y	Single		G	Y	Double	
 V	 W	Z	Q	Y	N		X	---	---	Special Type
			U	Y	Double					
1. Shape			4. Chip Breaker and Hole							
Code	Center Hole	Chip Breaker	Insert Profile	Code	Center Hole	Chip Breaker	Insert Profile			



32.00			32				
31.75			31				
25.40			25	25			
25.00	25	25	25				
20.00			20				
19.05	19		19	19	33		
16.00		19	16				
15.875	16		15	16	27		
12.70	12	15	12	12	22	22	08
12.00			12				
10.00			10				
9.525	09	11	09	09	16	16	06
8.00			08				
6.35	06	07			11	11	
6.00			06				
5.56					09		
5.50			05				
3.97					06		
Inscribed Circle diameter (mm)							
Insert Shape							
5. Cutting Edge Length							



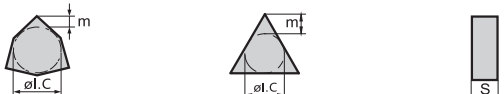

12	12.70
10	11.11
T9	9.72
09	9.52
07	7.94
T6	6.75
06	6.35
05	5.56
T4	4.96
04	4.76
T3	3.97
03	3.18
T2	2.78
02	2.38
T1	1.98
01	1.59
T0	0.99
00	0.79
Code	Thickness(mm)
	
6. Thickness	

**A P M T**

**16 04 PD E R - GM**

2. Clearance Angle				3. Tolerance										
Code	Clearance Angle	Code	Clearance Angle											
A	3°	B	5°	Code	m(mm)	d=I.C	S(mm)	Inscribed Circle	Regular Triangle	Square	80° Rhombus	55° Rhombus	35° Rhombus	
C	7°	D	15°	A	±0.005	±0.025	±0.025	6.35	±0.08	±0.08	±0.08	±0.11	±0.16	---
E	20°	F	25°	F	±0.005	±0.013	±0.025	9.525	±0.08	±0.08	±0.08	±0.11	±0.16	---
G	30°	N	0°	C	±0.013	±0.025	±0.025	12.7	±0.13	±0.13	±0.13	±0.15	---	---
P	11°	O	Others	H	±0.013	±0.013	±0.025	15.875	±0.15	±0.15	±0.15	±0.18	---	---
				E	±0.025	±0.025	±0.025	19.05	±0.15	±0.15	±0.15	±0.18	---	---
				G	±0.025	±0.025	±0.13	25.4	---	±0.18	---	---	---	---
				J	±0.005	±0.05±0.13	±0.025	♦ Tolerance of Inscribed Circle(mm)						
				K	±0.013	±0.05±0.13	±0.025	Inscribed Circle	Regular Triangle	Square	80° Rhombus	55° Rhombus	35° Rhombus	
				L	±0.025	±0.05±0.13	±0.025	6.35	±0.05	±0.05	±0.05	±0.05	±0.05	---
				M	±0.08±0.18	±0.05±0.13	±0.13	9.525	±0.05	±0.05	±0.05	±0.05	±0.05	±0.05
				N	±0.08±0.18	±0.05±0.13	±0.025	12.7	±0.08	±0.08	±0.08	±0.08	---	±0.08
				U	±0.13±0.38	±0.08±0.25	±0.13	15.875	±0.10	±0.10	±0.10	±0.10	---	±0.10
								19.05	±0.10	±0.10	±0.10	±0.10	---	±0.10
								25.4	---	±0.13	---	---	---	±0.13

7. Approach Angle/Relief Angle			
			
A	45°	A	3°
D	60°	B	5°
E	75°	C	7°
F	85°	D	15°
P	90°	E	20°
Z	other	F	25°
		G	30°
		N	0°
		P	11°
		Z	other

8. Cutting Edge Code			
			
F	0-5°	0-0.10	k(or no code)
E	1-10°	1-0.15	P
T	2-15°	2-0.20	W
S	3-20°	3-0.25	Q
	4-25°	4-0.30	
	5-30°	5-0.35	
	1-10°	6-0.40	
	1-10°	7-0.45	

10. Chip Breaker	
9. Cutting Direction Code	
R	Right
L	Left
N	Neutral



## Shoulder Milling Inserts

### APMT Inserts

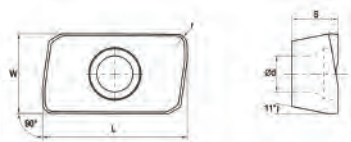

Length	Size(mm)			
	L	W	S	r
11	11.35	6.2	3.5	0.8
16	17.35	9.3	5.26	0.8

Shape	Type	ap (mm)	fz (mm/z)	CVD		PVD											
				GW0203	GW0403	GW0151	GW0251	GW8241	GW8251	GW5251	GW8281	GWFR0101	GWFR5201	GWFR5251	GWFR0291		
	APMT1135PDER-XR	2.50-7.50	0.05-0.25			○	●	○	●	●	○						
	APMT1605PDER-XR	3.50-10.00	0.07-0.50			○	●	○	●	●	○						

Note: ● The Recommended Grade ready to stock

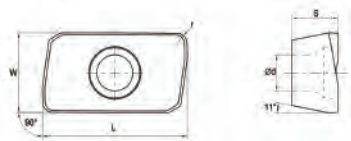

Length	Size(mm)			
	L	W	S	r
11	11.35	6.2	3.5	0.8
16	17.35	9.3	5.26	0.8

Shape	Type	ap (mm)	fz (mm/z)	CVD		PVD											
				GW0203	GW0403	GW0151	GW0251	GW8241	GW8251	GW5251	GW8281	GWFR0101	GWFR5201	GWFR5251	GWFR0291		
	APMT1135PDER-GM	2.50-7.50	0.05-0.25			○	●	○	●	●	○						
	APMT160408PDER-GM	3.50-10.00	0.07-0.50			○	●	○	●	●	○						

Note: ● The Recommended Grade ready to stock

### APMT Inserts

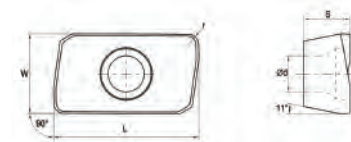

Length	Size(mm)			
	L	W	S	r
11	11.35	6.2	3.5	0.8
16	17.35	9.2	4.76	0.8

Shape	Type	ap (mm)	fz (mm/z)	CVD		PVD											
				GW0203	GW0403	GW0151	GW0251	GW8241	GW8251	GW5251	GW8281	GWFR0101	GWFR5201	GWFR5251	GWFR0291		
	APMT1135PDER-M2	2.50-7.50	0.05-0.25			○	●	○	●	●	○						
	APMT160408PDER-M2	3.50-10.00	0.07-0.30			○	●	○	●	●	○						

Note: ● The Recommended Grade ready to stock

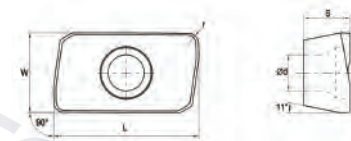

Length	Size(mm)			
	L	W	S	r
11	11.35	6.2	3.5	0.8
16	17.35	9.2	4.76	0.8

Shape	Type	ap (mm)	fz (mm/z)	CVD		PVD											
				GW0203	GW0403	GW0151	GW0251	GW8241	GW8251	GW5251	GW8281	GWFR0101	GWFR5201	GWFR5251	GWFR0291		
	APMT1135PDER-H2	2.50-7.50	0.05-0.25			○	●	○	●	●	○						
	APMT160408PDER-H2	3.50-10.00	0.07-0.30			○	●	○	●	●	○						

Note: ● The Recommended Grade ready to stock



## Shoulder Milling Inserts

### ADMT Inserts

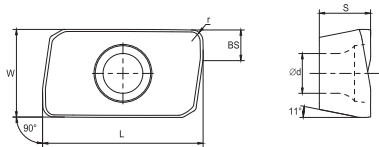

Length	Size(mm)				
	L	W	S	BS	r
11	11	6.7	3.8	1.4-2.1	0.2-1.2

Shape	Type	ap (mm)	fz (mm/z)	CVD		PVD												
				GW0203	GW0403	GW0151	GW0251	GW8241	GW8251	GW5251	GW8281	GW80101	GW85201	GW85251	GW80291			
	ADMT11T302ER-JT	2.0-6.0	0.06-0.15			○	●	○	●	●	○							
	ADMT11T304ER-JT	2.2-8.0	0.08-0.15			○	●	○	●	●	○							
	ADMT11T308ER-JT	2.5-10.0	0.10-0.18			○	●	○	●	●	○							
	ADMT11T312ER-JT	2.8-10.0	0.08-0.20			○	●	○	●	●	○							
	ADMT170408ER-JT	3.5-10.0	0.08-0.25			○	●	○	●	●	○							

Note: ● The Recommended Grade ready to stock

### TPKT Inserts

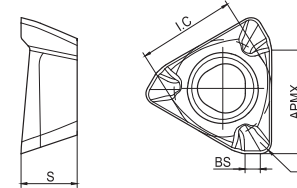

Length	Size(mm)				
	IC	S	APMX	BS	r
4	3.9	2.1	3.5	0.5-0.7	0.2-0.4
6	5.3	2.8	4.7	0.6-1.2	0.2-0.8
10	6.9	4	7	0.5-1.3	0.4-1.6
15	10.7	5	11	0.5-2.0	0.4-2.4
19	13.5	6	15	0.5-2.0	0.4-3.2

Shape	Type	ap (mm)	fz (mm/z)	CVD		PVD												
				GW0203	GW0403	GW0151	GW0251	GW8241	GW8251	GW5251	GW8281	GW80101	GW85201	GW85251	GW80291			
	TPKT040202R-M	0.50-3.00	0.04-0.08			○	●	○	●	●	○							
	TPKT040204R-M	0.50-3.00	0.04-0.08			○	●	○	●	●	○							
	TPKT060302R-M	1.00-4.00	0.04-0.10			○	●	○	●	●	○							
	TPKT060304R-M	1.00-4.00	0.04-0.10			○	●	○	●	●	○							
	TPKT060308R-M	1.00-4.00	0.04-0.10			○	●	○	●	●	○							
	TPKT100404R-M	2.00-6.00	0.05-0.12			○	●	○	●	●	○							
	TPKT100408R-M	2.00-6.00	0.05-0.12			○	●	○	●	●	○							
	TPKT100416R-M	2.00-6.00	0.05-0.12			○	●	○	●	●	○							
	TPKT150508R-M	3.00-9.00	0.07-0.17			○	●	○	●	●	○							
	TPKT150516R-M	3.00-9.00	0.07-0.17			○	●	○	●	●	○							
	TPKT150524R-M	3.00-12.00	0.07-0.17			○	●	○	●	●	○							
	TPKT190608R-M	4.50-12.00	0.09-0.22			○	●	○	●	●	○							
	TPKT190616R-M	4.50-12.00	0.09-0.22			○	●	○	●	●	○							
	TPKT190624R-M	4.50-12.00	0.09-0.22			○	●	○	●	●	○							
	TPKT190632R-M	4.50-12.00	0.09-0.22			○	●	○	●	●	○							

Note: ● The Recommended Grade ready to stock



## Shoulder Milling Inserts

### ANMX Inserts

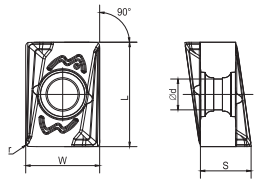

Length	Size(mm)					
	L	W	S	APMX	BS	r
11	11.85	8.4	5.7			0.4-0.8
15	15.430	11	7.3			0.8-1.6

Shape	Type	ap (mm)	fz (mm/z)	CVD		PVD											
				GW0203	GW0403	GW0151	GW0251	GW8241	GW8251	GW5251	GW8281	GWFR0101	GWFR5201	GWFR5251	GWFR0291		
	ANMX110504PNR	2.00-9.00	0.10-0.20			○	●	○	●	●	○						
	ANMX110508PNR	3.00-9.00	0.10-0.20			○	●	○	●	●	○						
	ANMX150608PNR	4.50-12.00	0.10-0.20			○	●	○	●	●	○						
	ANMX150616PNR	5.00-12.00	0.10-0.20			○	●	○	●	●	○						

Note: ● The Recommended Grade ready to stock

### ANKT Inserts

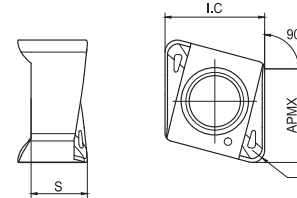

Length	Size(mm)				
	IC	S	APMX	BS	r
4	4	3.1	3.5	-	0.2-0.8
6	6.6	4.2-5.0	5.8-6.2	0.6-1.0	0.4-2.0
9	8.6	5.7-6.3	8	0.8-1.2	0.4-1.6
11	10.7	8.1	10.5	1	0.8

Shape	Type	ap (mm)	fz (mm/z)	CVD		PVD											
				GW0203	GW0403	GW0151	GW0251	GW8241	GW8251	GW5251	GW8281	GWFR0101	GWFR5201	GWFR5251	GWFR0291		
	ANKT040202R-M	0.50-3.00	0.04-0.08			○	●	○	●	●	○						
	ANKT040204R-M	1.00-3.00	0.06-0.12			○	●	○	●	●	○						
	ANKT040208R-M	1.00-3.00	0.06-0.12			○	●	○	●	●	○						
	ANKT060304R-M	0.50-5.00	0.07-0.15			○	●	○	●	●	○						
	ANKT060308R-M	1.00-5.00	0.07-0.15			○	●	○	●	●	○						
	ANKT060312R-M	1.00-5.00	0.07-0.15			○	●	○	●	●	○						
	ANKT060316R-M	2.00-4.50	0.07-0.15			○	●	○	●	●	○						
	ANKT060320R-M	2.00-4.50	0.07-0.15			○	●	○	●	●	○						
	ANKT090408R-M	2.50-7.00	0.07-0.15			○	●	○	●	●	○						
	ANKT090416R-M	2.50-7.00	0.07-0.15			○	●	○	●	●	○						
ANKT110608R-M	3.50-10.0	0.09-0.15			○	●	○	●	●	○							

Note: ● The Recommended Grade ready to stock



## Shoulder Milling Inserts

### LNGU Inserts

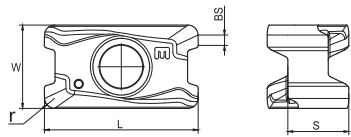

Length	Size(mm)				
	L	S	W	BS	r
11	12.16	4.83	6.6	1.4	0.4-1.2

Shape	Type	ap (mm)	fz (mm/z)	CVD		PVD											
				GW0203	GW0403	GW0151	GW0251	GW8241	GW8251	GW5251	GW8281	GWFR0101	GWFR5201	GWFR5251	GWFR0291		
	LNGU110404ERGE-GM	max=10	0.50-1.50			○	●	○	●	●	○						
	LNGU110408ERGE-GM	max=10	0.50-1.50			○	●	○	●	●	○						
	LNGU110412ERGE-GM	max=10	0.50-1.50			○	●	○	●	●	○						

Note: ●Recommended grade ready to stock

### XNEX Inserts

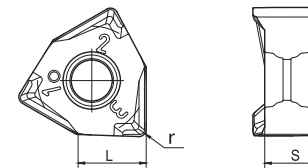

Length	Size(mm)	
	L	S
08	7.5	6.45

Shape	Type	ap (mm)	fz (mm/z)	CVD		PVD											
				GW0203	GW0403	GW0151	GW0251	GW8241	GW8251	GW5251	GW8281	GWFR0101	GWFR5201	GWFR5251	GWFR0291		
	XNEX080608TR-GL	0.80-8.00	0.10-0.30			○	●	○	●	●	○						
	XNEX080612TR-GL	0.80-8.00	0.10-0.30			○	●	○	●	●	○						
	XNEX080608TR-GM	0.80-8.00	0.10-0.30			○	●	○	●	●	○						

Note: ●Recommended grade ready to stock

### WNMU Inserts

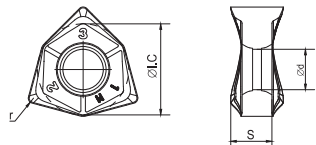

Length	Size(mm)		
	S	d	r
5	4.2	3.4	0.8
8	6.65	6.2	0.8

Shape	Type	ap (mm)	fz (mm/z)	CVD		PVD											
				GW0203	GW0403	GW0151	GW0251	GW8241	GW8251	GW5251	GW8281	GWFR0101	GWFR5201	GWFR5251	GWFR0291		
	WNMU050408EN-GM	0.50-5.00	0.10-0.30			○	●	○	●	●	○						
	WNMU080608EN-GM	0.80-8.00	0.10-0.30			○	●	○	●	●	○						

Note: ●Recommended grade ready to stock



## Shoulder Milling Inserts

### RPMW Inserts

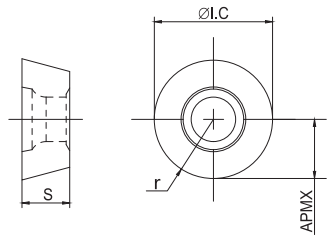

Length	Size(mm)			
	r	I.C	S	APMX
8	4	8	2.78	4
10	5	10	3.18	5
12	6	12	4.76	6

Shape	Type	ap (mm)	fz (mm/z)	CVD		PVD												
				GW0203	GW0403	GW0151	GW0251	GW8241	GW8251	GW5251	GW8281	GWR0101	GWR5201	GWR5251	GWR0291			
	RPMW08T2MO	1.00-3.00	0.05-0.25			○	●	○	●	●	○							
	RPMW1003MO	1.50-4.00	0.05-0.30			○	●	○	●	●	○							
	RPMW1204MO	1.50-5.00	0.05-0.35			○	●	○	●	●	○							

Note: ● The Recommended Grade ready to stock

### RPMT Inserts

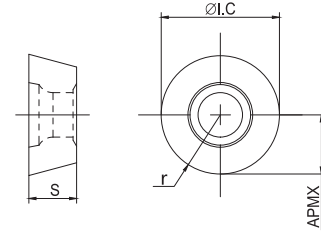

Length	Size(mm)			
	r	I.C	S	APMX
8	4	8	2.78	4
10	5	10	3.18	5
12	6	12	4.76	6

Shape	Type	ap (mm)	fz (mm/z)	CVD		PVD												
				GW0203	GW0403	GW0151	GW0251	GW8241	GW8251	GW5251	GW8281	GWR0101	GWR5201	GWR5251	GWR0291			
	RPMT08T2MO-GM	1.50-4.00	0.10-0.30			○	●	○	●	●	○							
	RPMT10T3MO-GM	1.80-5.00	0.10-0.50			○	●	○	●	●	○							
	RPMT1204MO-GM	2.00-6.50	0.10-0.50			○	●	○	●	●	○							

Note: ● The Recommended Grade ready to stock

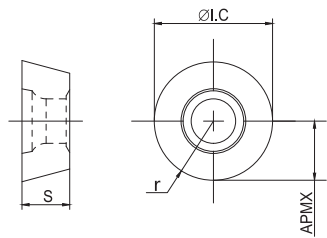

Length	Size(mm)			
	r	I.C	S	APMX
8	4	8	2.78	4
10	5	10	3.97	5
12	6	12	4.76	6
16	8	16	6.35	8

Shape	Type	ap (mm)	fz (mm/z)	CVD		PVD												
				GW0203	GW0403	GW0151	GW0251	GW8241	GW8251	GW5251	GW8281	GWR0101	GWR5201	GWR5251	GWR0291			
	RPMT08T2MOE-JM	1.00-1.30	0.05-0.25			○	●	○	●	●	○							
	RPMT10T3MOE-JM	1.50-4.00	0.05-0.30			○	●	○	●	●	○							
	RPMT1204MOE-JM	1.50-5.00	0.05-0.35			○	●	○	●	●	○							
	RPMT1606MOE-JM	2.00-6.50	0.10-0.40			○	●	○	●	●	○							

Note: ● The Recommended Grade ready to stock



## Profile Milling Inserts

### RDKT Inserts

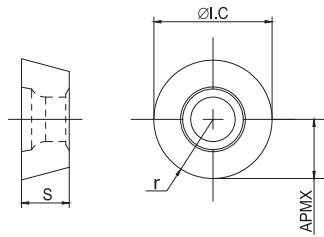

Length	Size(mm)			
	r	I.C	S	APMX
8	4	8	3.18	4
10	5	10	3.97	5
12	6	12	4.76	6
16	8	16	5.56	8
20	10	20	6.35	10

### RPMT Inserts

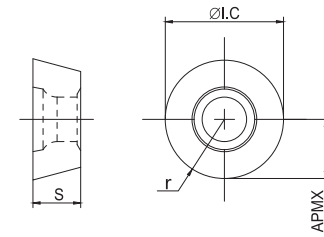

Length	Size(mm)			
	r	I.C	S	APMX
8	4	8	2.78	4
10	5	10	3.97	5
12	6	12	4.76	6

Shape	Type	ap (mm)	fz (mm/z)	CVD		PVD											
				GW0203	GW0403	GW0151	GW0251	GW8241	GW8251	GW5251	GW8281	GWR0101	GWR5201	GWR5251	GWR0291		
	RDKT0803MO	1.00-3.00	0.05-0.25			○	●	○	●	●	○						
	RDKT10T3MO	1.50-4.00	0.05-0.30			○	●	○	●	●	○						
	RDKT1204MO	1.50-5.00	0.05-0.35			○	●	○	●	●	○						
	RDKT1604MO	2.00-6.50	0.10-0.40			○	●	○	●	●	○						
	RDKT1605MO	2.00-6.50	0.10-0.40			○	●	○	●	●	○						
	RDKT1606MO	2.00-6.50	0.10-0.40			○	●	○	●	●	○						
	RDKT2006MO	3.00-8.00	0.10-0.40			○	●	○	●	●	○						

Note: ● The Recommended Grade ready to stock

Shape	Type	ap (mm)	fz (mm/z)	CVD		PVD											
				GW0203	GW0403	GW0151	GW0251	GW8241	GW8251	GW5251	GW8281	GWR0101	GWR5201	GWR5251	GWR0291		
	RPMT0803-XR	1.00-1.30	0.05-0.25			○	●	○	●	●	○						
	RPMT10T3-XR	1.50-4.00	0.05-0.30			○	●	○	●	●	○						
	RPMT1204-XR	1.50-5.00	0.05-0.35			○	●	○	●	●	○						

Note: ● The Recommended Grade ready to stock



## Profile Milling Inserts

### RPMT Inserts

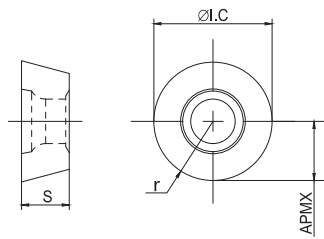

Length	Size(mm)			
	r	I.C	S	APMX
8	4	8	2.78	4
10	5	10	3.97	5
12	6	12	4.76	6

Shape	Type	ap (mm)	fz (mm/z)	CVD		PVD											
				GW0203	GW0403	GW0151	GW0251	GW8241	GW8251	GW5251	GW8281	GWR0101	GWR5201	GWR5251	GWR0291		
	RPMT08T2MO	1.5-4.0	0.1-0.3			○	●	○	●	●	○						
	RPMT10T3MO	1.8-5.0	0.1-0.5			○	●	○	●	●	○						
	RPMT1204MO	2-6.5	0.1-0.5			○	●	○	●	●	○						

Note: ● The Recommended Grade ready to stock

## High Feed Milling Inserts

### EPNW Inserts

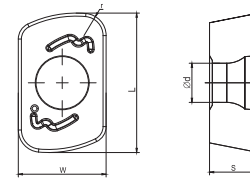

Size(mm)				
W	S	d	L	r
6.28	3.18	2.8	9.79	1.6

Shape	Type	ap (mm)	fz (mm/z)	CVD		PVD											
				GW0203	GW0403	GW0151	GW0251	GW8241	GW8251	GW5251	GW8281	GWR0101	GWR5201	GWR5251	GWR0291		
	EPNW0603TN-GH	max=1.5	0.15-0.50			○	●	○	●	●	○						

### LPGT Inserts

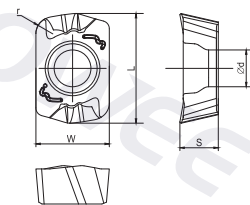

Size(mm)				
W	S	d	L	r
4.19	2.19	2.1	6.26	1

Shape	Type	ap (mm)	fz (mm/z)	CVD		PVD											
				GW0203	GW0403	GW0151	GW0251	GW8241	GW8251	GW5251	GW8281	GWR0101	GWR5201	GWR5251	GWR0291		
	LPGT010210ER-GM	max=1	0.50-1.50			○	●	○	●	●	○						

Note: ● The Recommended Grade ready to stock



## High Feed Milling Inserts

### SDMT Inserts

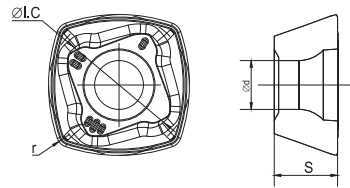

Length	Size(mm)		
	I.C	S	r
12	12.7	5.56	1.2
15	15.875	5.56	1.2

Shape	Type	ap (mm)	fz (mm/z)	CVD		PVD											
				GW0203	GW0403	GW0151	GW0251	GW8241	GW8251	GW5251	GW8281	GWFR0101	GWFR5201	GWFR5251	GWFR0291		
	SDMT120512-GM	0.50-2.00	0.60-1.20			○	●	○	●	●	○						
	SDMT150512-GM	0.80-3.00	0.60-1.20			○	●	○	●	●	○						
						○	●	○	●	●	○						
						○	●	○	●	●	○						

Note: ● The Recommended Grade ready to stock

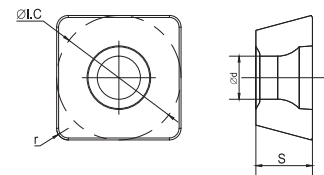

Length	Size(mm)		
	I.C	S	r
6	6.35	2.58	0.8
9	9.525	3.97	1.2
12	12.7	4.76	1.2
15	15.875	5.56	2

Shape	Type	ap (mm)	fz (mm/z)	CVD		PVD											
				GW0203	GW0403	GW0151	GW0251	GW8241	GW8251	GW5251	GW8281	GWFR0101	GWFR5201	GWFR5251	GWFR0291		
	SDMT06T208-GH	0.50-1.20	0.50-1.00			○	●	○	●	●	○						
	SDMT09T312-GH	0.50-1.80	0.50-1.00			○	●	○	●	●	○						
	SDMT120412-GH	0.50-2.00	0.60-1.20			○	●	○	●	●	○						
	SDMT150520-GH	0.80-3.00	0.60-1.20			○	●	○	●	●	○						

Note: ● The Recommended Grade ready to stock

### SOMT Inserts

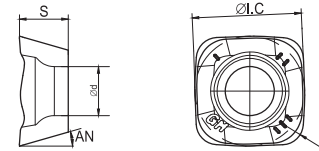

Length	Size(mm)				
	I.C	S	d	r	AN(°)
10	10.3	4.58	4.6	2	16

Shape	Type	ap (mm)	fz (mm/z)	CVD		PVD											
				GW0203	GW0403	GW0151	GW0251	GW8241	GW8251	GW5251	GW8281	GWFR0101	GWFR5201	GWFR5251	GWFR0291		
	SOMT100420ER-GM	0.10-1.20	0.20-2.00			○	●	○	●	●	○						

Note: ● The Recommended Grade ready to stock

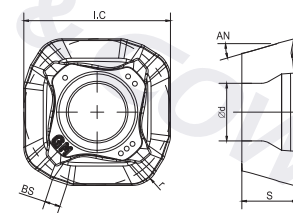

Length	Size(mm)					
	I.C	S	d	BS	r	AN(°)
14	14.76	5.56	5.8	1.6	2	16

Shape	Type	ap (mm)	fz (mm/z)	CVD		PVD											
				GW0203	GW0403	GW0151	GW0251	GW8241	GW8251	GW5251	GW8281	GWFR0101	GWFR5201	GWFR5251	GWFR0291		
	SOMT140520ER-GH	0.50-2.00	0.42-2.00			○	●	○	●	●	○						

Note: ● The Recommended Grade ready to stock



## High Feed Milling Inserts

### LNMU Inserts

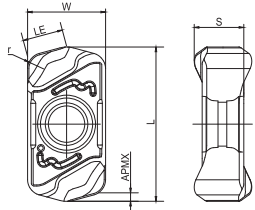

Length	Size(mm)				
	r	APMX	L	I.C	S
3	1.2	1	3.2	6	4.3

Shape	Type	ap (mm)	fz (mm/z)	CVD		PVD													
				GW0203	GW0403	GW0151	GW0251	GW8241	GW8251	GW5251	GW8281	GWR0101	GWR5201	GWR5251	GWR0291				
	LNMU0303ZER-GM	0.20-2.00	0.50-1.30			○	●	○	●	●	○								

Note: ● The Recommended Grade ready to stock

### LOGU Inserts

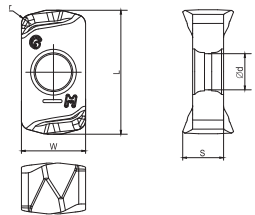

Length	Size(mm)				
	W	S	d	L	r
3	6.2	3.96	3.45	11.9	1

Shape	Type	ap (mm)	fz (mm/z)	CVD		PVD													
				GW0203	GW0403	GW0151	GW0251	GW8241	GW8251	GW5251	GW8281	GWR0101	GWR5201	GWR5251	GWR0291				
	LOGU030310ER-GM	max=1	0.50-1.50			○	●	○	●	●	○								

Note: ● The Recommended Grade ready to stock

### BLMP Inserts

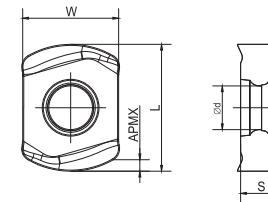

Length	Size(mm)			
	L	W	S	APMX
4	6	4.2	2.5	0.5
6	9	6.39	3.73	1
9	11.9	9.18	4.8	1.5
11	14.6	11.2	6.5	2

Shape	Type	ap (mm)	fz (mm/z)	CVD		PVD													
				GW0203	GW0403	GW0151	GW0251	GW8241	GW8251	GW5251	GW8281	GWR0101	GWR5201	GWR5251	GWR0291				
	BLMP0402R-GM	0.10-0.50	0.20-1.50			○	●	○	●	●	○								
	BLMP0603R-GM	0.10-1.00	0.30-2.50			○	●	○	●	●	○								
	BLMP0904R-GM	0.10-1.50	0.30-3.50			○	●	○	●	●	○								
	BLMP1105R-GM	0.30-2.00	0.30-4.00			○	●	○	●	●	○								

Note: ● The Recommended Grade ready to stock



# Milling Inserts

GREWIN&COWEE  
CUTTING TOOLS

## Heat Resistant Alloys / Titanium Alloys

### RPHX Inserts

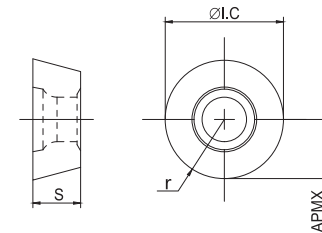

Length	Size(mm)			
	r	I.C	S	APMX
10	5	10	3.97	5
12	6	12	4.76	6

Shape	Type	ap (mm)	fz (mm/z)	CVD				PVD							
				GW1153	GW2134	GW2234	GW2354	GW0251	GW5251	GW5281	GW8241	GW5201	GW6101	GW5251	GW6321
	RPHX10T3-DF	1.50-4.00	0.05-0.30										●	●	○
	RPHX1204-DF	1.50-5.00	0.05-0.35										●	●	○

Note: ● The Recommended Grade ready to stock

### RPHX Inserts

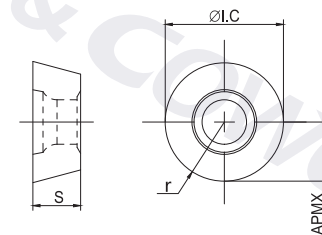

Length	Size(mm)			
	r	I.C	S	APMX
10	5	10	3.18	5
12	6	12	4.76	6

Shape	Type	ap (mm)	fz (mm/z)	CVD				PVD							
				GW1153	GW2134	GW2234	GW2354	GW0251	GW5251	GW5281	GW8241	GW5201	GW6101	GW5251	GW6321
	RPHX10T3-DM	1.80-5.00	0.10-0.50										●	●	○
	RPHX1204-DM	2.00-6.50	0.10-0.50										●	●	○

Note: ● The Recommended Grade ready to stock





## Heat Resistant Alloys / Titanium Alloys

### APMT Inserts

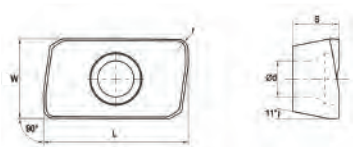

Length	Size(mm)			
	L	W	S	r
11	11.4	6.2	3.5	0.8
16	17.25	9.2	4.76	0.8、3

Shape	Type	ap (mm)	fz (mm/z)	CVD				PVD										
				GW1153	GW2134	GW2234	GW2354	GW0251	GW5251	GW5281	GW8241	GWR5201	GWR6101	GWR5251	GWR6321	GWR0291		
	APMT1135PDER-DF	2.5-7.5	0.05-0.25													●	●	○
	APMT160408PDER-DF	3.5-10	0.07-0.5													●	●	○
	APMT160430PDER-DF	5.0-10	0.2-0.5													●	●	○
	APMT1135PDER-DM	2.5-7.5	0.05-0.35													●	●	○
	APMT160408PDER-DM	3.5-10	0.2-0.7													●	●	○

Note: ● The Recommended Grade ready to stock

### LNMU Inserts

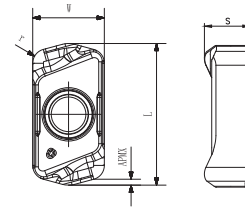

Length	Size(mm)				
	W	S	APMX	L	r
3	6	3.75	1	11.8	1.2

Shape	Type	ap (mm)	fz (mm/z)	CVD				PVD										
				GW1153	GW2134	GW2234	GW2354	GW0251	GW5251	GW5281	GW8241	GWR5201	GWR6101	GWR5251	GWR6321	GWR0291		
	LNMU0303ZER-MS	0.2-2.0	0.5-1.3													●	●	○

Note: ● The Recommended Grade ready to stock

### SDMT Inserts

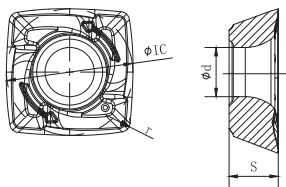

Length	Size(mm)		
	I.C	S	r
6	6.35	2.78	0.5
9	9	3.5	0.7

Shape	Type	ap (mm)	fz (mm/z)	CVD				PVD										
				GW1153	GW2134	GW2234	GW2354	GW0251	GW5251	GW5281	GW8241	GWR5201	GWR6101	GWR5251	GWR6321	GWR0291		
	SDMT06T205-DM		0.1-1.0													●	●	○
	SDMT09T307-DM		0.2-1.2													●	●	○

Note: ● The Recommended Grade ready to stock



## 45° Face Milling Inserts

### SEMU Inserts

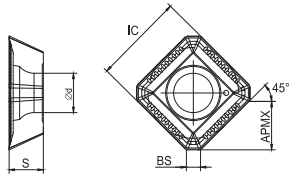

Length	Size(mm)			
	BS	APMX	I.C	S
12	1.5	6.5	12.7	4.76

Shape	Type	ap (mm)	fz (mm/z)	CVD		PVD												
				GW0203	GW0403	GW0151	GW0251	GW8241	GW8251	GW5251	GW8281	GWR0101	GWR5201	GWR5251	GWR0291			
	SEMT1204AFTN-GM	3.00-8.50	0.09-0.16			○	●	○	●	●	○							

Note: ● The Recommended Grade ready to stock

### SEER Inserts

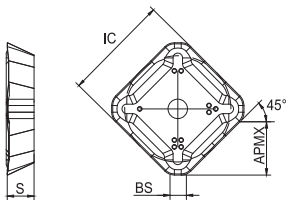

Length	Size(mm)			
	BS	APMX	I.C	S
12	1.5	6.5	12.7	3.19
15	2	8.5	15.875	4.76

Shape	Type	ap (mm)	fz (mm/z)	CVD		PVD												
				GW0203	GW0403	GW0151	GW0251	GW8241	GW8251	GW5251	GW8281	GWR0101	GWR5201	GWR5251	GWR0291			
	SEER1203-GM	1.50-6.00	0.10-0.25			○	●	○	●	●	○							
	SEER1504-GM	1.50-8.00	0.10-0.25			○	●	○	●	●	○							

Note: ● The Recommended Grade ready to stock

## 88° Approaching Angle Cost-effective Face Milling Inserts

### SNMU Inserts

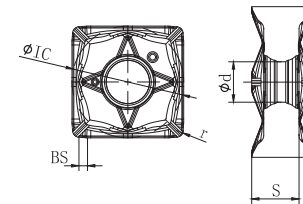

Length	Size(mm)			
	I.C	S	BS	r
13	13	5.5	1	0.8

Shape	Type	ap (mm)	fz (mm/z)	CVD		PVD												
				GW0203	GW0403	GW0151	GW0251	GW8241	GW8251	GW5251	GW8281	GWR0101	GWR5201	GWR5251	GWR0291			
	SNMU130508EN-GM	1.0-5.0	0.1-0.25			○	●	○	●	●	○							

Note: ● The Recommended Grade ready to stock



## Cost-effective Face Milling Inserts

### SNMX Inserts

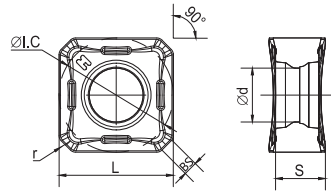

Length	Size(mm)		
	I.C	S	BS
12	12.7	6.4	1.5
16	16	7.7	1.8

Shape	Type	ap (mm)	fz (mm/z)	CVD		PVD											
				GW0203	GW0403	GW0151	GW0251	GW8241	GW8251	GW5251	GW8281	GWFR0101	GWFR5201	GWFR5251	GWFR0291		
	SNMX1205ANN-GM	1.00-6.00	0.15-0.50			○	●	○	●	●	○						
	SNMX1606ANN-GM	1.00-6.00	0.15-0.50			○	●	○	●	●	○						

Note: ● The Recommended Grade ready to stock

### PNCU Inserts

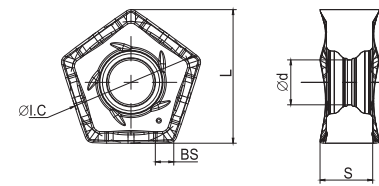

Length	Size(mm)				
	L	S	d	BCH	BS
09	12.2	13.4	5.35	4.5	2

Shape	Type	ap (mm)	fz (mm/z)	CVD		PVD											
				GW0203	GW0403	GW0151	GW0251	GW8241	GW8251	GW5251	GW8281	GWFR0101	GWFR5201	GWFR5251	GWFR0291		
	PNCU0905GNEN-GM	0.50-3.00	0.20-0.60			○	●	○	●	●	○						

Note: ● The Recommended Grade ready to stock

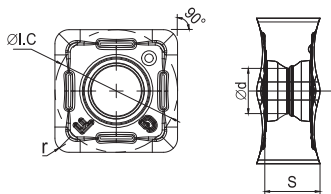

Length	Size(mm)		
	I.C	S	r
9	9.525	5.5	0.8-1.1

Shape	Type	ap (mm)	fz (mm/z)	CVD		PVD											
				GW0203	GW0403	GW0151	GW0251	GW8241	GW8251	GW5251	GW8281	GWFR0101	GWFR5201	GWFR5251	GWFR0291		
	SNGX090408-GF	2.50-7.50	0.08-0.15			○	●	○	●	●	○						
	SNGX090411-GF	2.50-7.50	0.08-0.15			○	●	○	●	●	○						

Note: ● The Recommended Grade ready to stock



## Cost-effective Face Milling Inserts

### HNMG Inserts

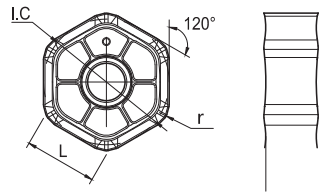

Length	Size(mm)		
	I.C	S	r
9	16.5	6.35	1.0

Shape	Type	ap (mm)	fz (mm/z)	CVD		PVD												
				GW0203	GW0403	GW0151	GW0251	GW8241	GW8251	GW5251	GW8281	GWR0101	GWR5201	GWR5251	GWR0291			
	HNMG0907ANSN-R	1.50-4.00	0.20-0.70			○	●	○	●	●	○							

Note: ● The Recommended Grade ready to stock

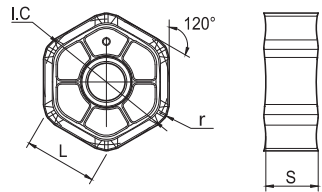

Length	Size(mm)		
	I.C	S	r
9	16.5	6.35	1.0

Shape	Type	ap (mm)	fz (mm/z)	CVD		PVD												
				GW0203	GW0403	GW0151	GW0251	GW8241	GW8251	GW5251	GW8281	GWR0101	GWR5201	GWR5251	GWR0291			
	HNMG0907ANSN-M	1.00-3.00	0.05-0.15			○	●	○	●	●	○							

Note: ● The Recommended Grade ready to stock

## Cost-effective Face Milling Inserts

### XNMU Inserts

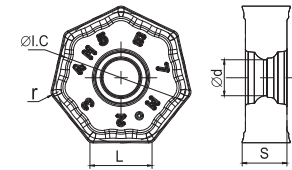

Length	Size(mm)			
	I.C	S	d	r
7	12	5.8	4	0.8

Shape	Type	ap (mm)	fz (mm/z)	CVD		PVD												
				GW0203	GW0403	GW0151	GW0251	GW8241	GW8251	GW5251	GW8281	GWR0101	GWR5201	GWR5251	GWR0291			
	XNMU070508-MM	0.2-3.0	0.05-0.2			○	●	○	●	●	○							

Note: ● The Recommended Grade ready to stock

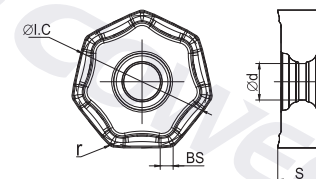

Length	Size(mm)				
	I.C	S	d	BS	r
9	19.05	5.9	5.5	1.5	1.2

Shape	Type	ap (mm)	fz (mm/z)	CVD		PVD												
				GW0203	GW0403	GW0151	GW0251	GW8241	GW8251	GW5251	GW8281	GWR0101	GWR5201	GWR5251	GWR0291			
	XNMU090612-GR	0.3-3.0	0.05-0.3			○	●	○	●	●	○							

Note: ● The Recommended Grade ready to stock



## Cost-effective Face Milling Inserts

## Cost-effective Face Milling Inserts

### ONHU Inserts

### ONMU Inserts

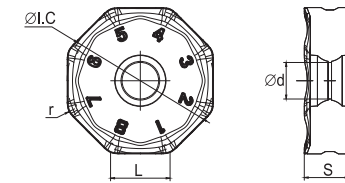
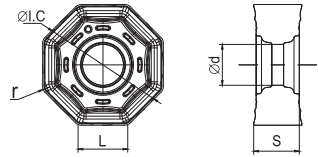

Length	Size(mm)		
	I.C	S	r
05	12.7	4.76	0.8

Length	Size(mm)		
	I.C	S	BS
09	22	5.8	0.45
09	22	5.8	2.11

Shape	Type	ap (mm)	fz (mm/z)	CVD		PVD												
				GW0203	GW0403	GW0151	GW0251	GW8241	GW8251	GW8281	GWFR0101	GWFR5201	GWFR5251	GWFR0291				
	ONHU050408-AR	0.8-3.5	0.2-0.35			○	●	○	●	●	○							

Shape	Type	ap (mm)	fz (mm/z)	CVD		PVD												
				GW0203	GW0403	GW0151	GW0251	GW8241	GW8251	GW8281	GWFR0101	GWFR5201	GWFR5251	GWFR0291				
	ONMU090520ANTN-GM	0.80-2.50	0.10-0.20			○	●	○	●	●	○							
	ONMU090520ANTN-GR	1.00-3.50	0.10-0.20			○	●	○	●	●	○							

Note: ● The Recommended Grade ready to stock

Note: ● The Recommended Grade ready to stock

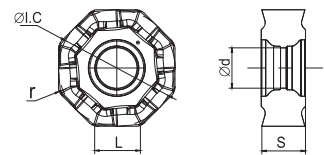

Length	Size(mm)		
	I.C	S	r
05	12.7	4.76	0.8

Shape	Type	ap (mm)	fz (mm/z)	CVD		PVD												
				GW0203	GW0403	GW0151	GW0251	GW8241	GW8251	GW8281	GWFR0101	GWFR5201	GWFR5251	GWFR0291				
	ONHU050408-AF	0.5-2.5	0.1-0.25			○	●	○	●	●	○							

Note: ● The Recommended Grade ready to stock



## Helix Milling Inserts

### APKT Inserts

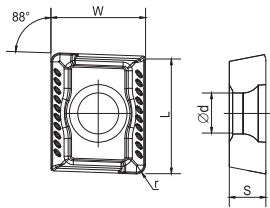

Length	Size(mm)				
	L	W	S	d	r
15	16.33	12.7	4.76	5.4	1.2

Shape	Type	ap (mm)	fz (mm/z)	CVD		PVD											
				GW0203	GW0403	GW0151	GW0251	GW8241	GW8251	GW5251	GW8281	GWR0101	GWR5201	GWR5251	GWR0291		
	APKT150412-PM	1.2-8	0.08-0.2			○	●	○	●	●	○						
	APKT150415-KM	1.2-8	0.08-0.2			○	●	○	●	●	○						

Note: ● The Recommended Grade ready to stock

### SPMT Inserts

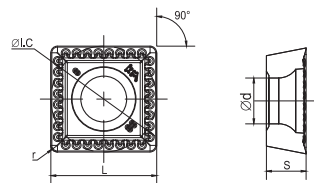

Length	Size(mm)				
	r	L	L.C	S	d
12	0.8	12.7	12.7	4.76	5.5

Shape	Type	ap (mm)	fz (mm/z)	CVD		PVD											
				GW0203	GW0403	GW0151	GW0251	GW8241	GW8251	GW5251	GW8281	GWR0101	GWR5201	GWR5251	GWR0291		
	SPMT120408-PM	1.00-6.00	0.06-0.15			○	●	○	●	●	○						
	SPMT120408-KM	1.00-6.00	0.06-0.15			○	●	○	●	●	○						

Note: ● The Recommended Grade ready to stock

## Helical Milling Inserts

### CNHX Inserts

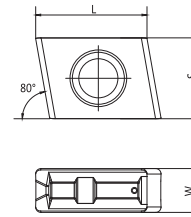

Type	Size(mm)		
	L	S	W
160608T	16	12	6.4

Shape	Type	ap (mm)	fz (mm/z)	CVD		PVD											
				GW0203	GW0403	GW0151	GW0251	GW8241	GW8251	GW5251	GW8281	GWR0101	GWR5201	GWR5251	GWR0291		
	CNHX160608T	1.20-5.50	0.20-0.60			○	●	○	●	●	○						

Note: ● The Recommended Grade ready to stock

### LNKT Inserts

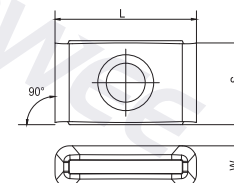

Type	Size(mm)		
	L	S	W
16090416	16	9.5	4.76

Shape	Type	ap (mm)	fz (mm/z)	CVD		PVD											
				GW0203	GW0403	GW0151	GW0251	GW8241	GW8251	GW5251	GW8281	GWR0101	GWR5201	GWR5251	GWR0291		
	LNKT16090416	1.60-12.00	0.15-0.50			○	●	○	●	●	○						

Note: ● The Recommended Grade ready to stock



## LNKX Inserts

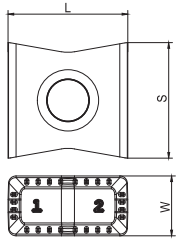

Type	Size(mm)		
	L	S	W
120608	12.7	12.25	6.35

Shape	Type	ap (mm)	fz (mm/z)	CVD		PVD											
				GW0203	GW0403	GW0151	GW0251	GW8241	GW8251	GW5251	GW8281	GWFR0101	GWFR5201	GWFR5251	GWFR0291		
	LNKX120608	2.00-7.00	0.10-0.20			○	●	○	●	●	○						

Note: ● The Recommended Grade ready to stock

# Drilling Inserts

GREWIN&COWEE  
CUTTING TOOLS





## WCMT Inserts

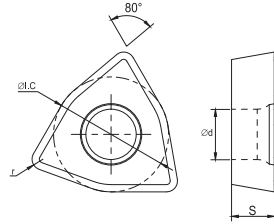

Shape	Type	Boring Range (mm)	Size					Application	Grade	
			L	øl.C	S	Ød	r		PVD	
									GW0251	GW8251
	WCMT030208-GM	16-20	3.8	5.56	2.38	2.8	0.8	Semi-finishing	●	●
	WCMT040208-GM	21-25	4.3	6.35	2.38	3.1	0.8		●	●
	WCMT050308-GM	26-30	5.4	7.94	3.18	3.2	0.8		●	●
	WCMT06T308-GM	31-41	6.5	9.525	3.97	3.7	0.8		●	●
	WCMT080412-GM	42-58	8.7	12.7	4.76	4.3	1.2		●	●
	WCMT030208-GF	16-20	3.8	5.56	2.38	2.8	0.8	Finishing	●	●
	WCMT040208-GF	21-25	4.3	6.35	2.38	3.1	0.8		●	●
	WCMT050308-GF	26-30	5.4	7.94	3.18	3.2	0.8		●	●
	WCMT06T308-GF	31-41	6.5	9.525	3.97	3.7	0.8		●	●
	WCMT080412-GF	42-58	8.7	12.7	4.76	4.3	1.2		●	●

Note: ● The Recommended Grade ready to stock

## SPMT Inserts

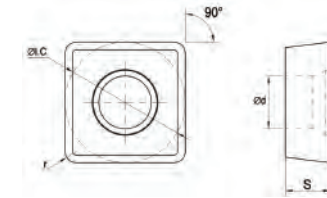

Shape	Type	Boring Range (mm)	Size					Application	Grade	
			L	øl.C	S	Ød	r		PVD	
									GW0251	GW8251
	SPMT050204-GM	12.5-15	5	5	2.38	2.2	0.4	Semi-finishing	●	●
	SPMT060204-GM	15.5-21.5	6	6	2.38	2.6	0.4		●	●
	SPMT07T308-GM	22-27.5	7.94	7.94	3.97	2.8	0.8		●	●
	SPMT090408-GM	28-33	9.8	9.8	4.3	4.2	0.8		●	●
	SPMT110408-GM	34-41	11.5	11.5	4.76	4.4	0.8		●	●
	SPMT140512-GM	42-50	14.3	14.3	5.2	5.75	1.2		●	●

Note: ● The Recommended Grade ready to stock



## SOMT Inserts

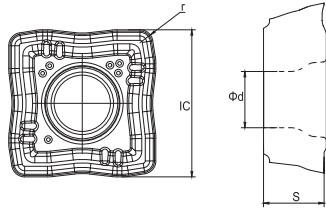

Shape	Type	Boring Range (mm)	Size					Application	Grade	
			L	$\phi$ I.C	S	$\Phi d$	r		PVD	
			GW0251	GW8251						
	SOMT040204-VP	13-16	1	4.4	2.38	2.2	0.4	Semi-finishing	●	●
	SOMT050204-VP	13-16	1.2	4.9	2.38	2.2	0.4		●	●
	SOMT060204-VP	16.5-17	1.8	5.7	2.38	2.6	0.4		●	●
	SOMT070306-VP	17.5-19	1.8	6.8	2.8	2.6	0.6		●	●
	SOMT08T306-VP	22.5-26.5	2	7.8	3.97	2.8	0.6		●	●
	SOMT09T308-VP	27.5-31.5	2.4	9.2	3.97	3.8	0.8		●	●
	SOMT11T308-VP	32-36.5	3	11	3.97	3.8	0.8		●	●
	SOMT130408-VP	37-43	3.2	12.8	4.4	4.5	0.8		●	●

Note: ● The Recommended Grade ready to stock

## SO SPMT Inserts

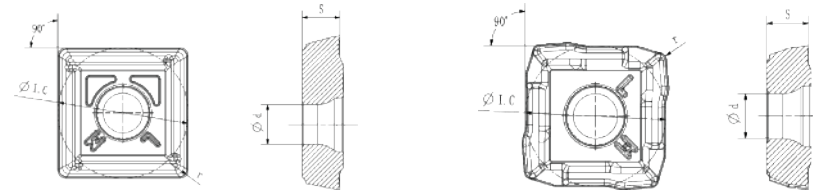

Shape	Type	Boring Range (mm)	Size				Application	Grade	
			$\phi$ I.C	S	$\Phi d$	r		PVD	
			GW0251	GW8251					
	SOMT050305C-LM	24-29	8.40	3.00	3.20	0.50	Medium Machining	●	●
	SOMT060406C-LM	30-41	10.20	3.50	4.00	0.60		●	●
	SOMT070406C-LM	30-41	12.36	4.00	4.00	0.60		●	●
	SOMT080508C-LM	44-63	14.90	4.50	4.70	0.80		●	●
	SOMT090608C-LM	44-63	17.90	5.50	4.70	0.80		●	●
	SPMT050308P-LM	24-29	8.90	3.00	3.20	0.80	Medium Machining	●	●
	SPMT060408P-LM	30-41	10.70	3.50	4.00	0.80		●	●
	SPMT070410P-LM	30-41	12.70	3.95	4.00	1.00		●	●
	SPMT080510P-LM	44-63	15.50	4.50	4.70	1.00		●	●
	SPMT090610P-LM	44-63	18.60	5.50	4.70	1.00	●	●	

Note: ● The Recommended Grade ready to stock



## Part One: General Technical Information for Turning Machining

### The Functions of Each Part of Turning Tools

#### 1 The Names of Each Part of Turning Tools

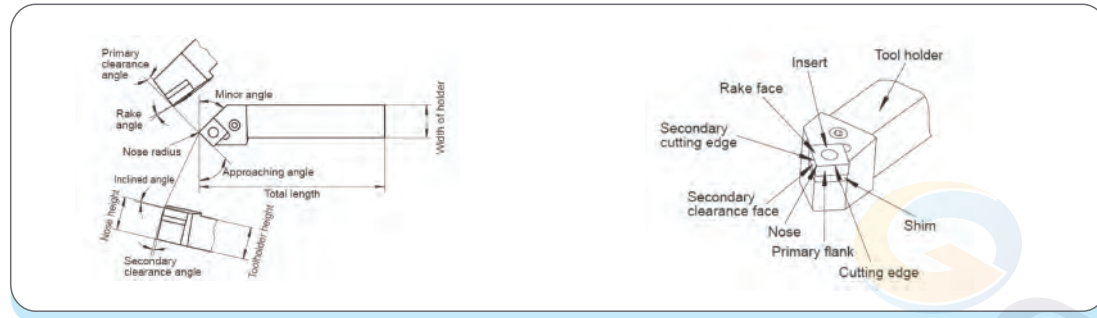

#### 2 Effects of Rake Angle

Larger rake angle makes cutting edge sharper, reduces resistant forces of chip flow, diminishes friction and prevent deformation, leading to smaller, less abrasion and higher surface quality. However, too large rake angle would reduce the rigidity and strength of tool. Heat can't be diffused easily, Serious breakage and abrasion on tool would occur, reducing tool life. Please choose rake angle according to machining conditions.

Value selection	Situations
Small rake angle	<ul style="list-style-type: none"> <li>When machining brittle and hard materials;</li> <li>When roughing and interrupted cutting</li> </ul>
Big rake angle	<ul style="list-style-type: none"> <li>When machining Plastic or soft materials;</li> <li>When finishing;</li> </ul>

#### 3 Effects of Clearance Angle

The main function of clearance angle to reduce the friction between the clearance face of tool and the surface of workpiece. When the rake angle is fixed, larger clearance angle can increase and the achieve higher surface quality. However, if clearance angle is too large, the strength of cutting edge would decrease. Also, heat can't be diffused easily and serious abrasion would occur, reducing tool life. The principle of choosing clearance angle: Choose small clearance angle if friction is not serious

Value selection	Situations
Small clearance angle	<ul style="list-style-type: none"> <li>In order to increase nose strength when roughing</li> <li>When machining brittle and hard materials</li> </ul>
Large clearance angle	<ul style="list-style-type: none"> <li>In order to reduce friction when finishing</li> <li>When machining materials easy to be hardened;</li> </ul>

#### 4 Effects of Inclined Angle

Positive or negative inclined angle determines the direction of chip flow, and also affects the strength and impact resistance of insert nose.

◆ As diagram(1) shows, when the inclined angle is negative, namely nose is in the lowest point as apposed to the bottom of tool, chips flow to the machined surface of workpiece.

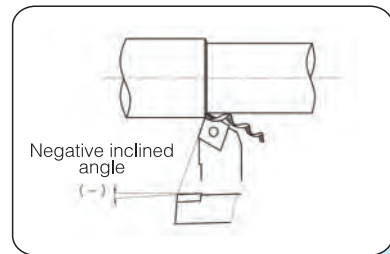

◆ As diagram(2) shows, when inclined angle is positive, namely the nose is in the highest point as apposed to the bottom of the tool, chips flow to the areas of workpiece surface that haven't been machined.

◆ The change of inclined angle also affects insert nose strength and impact resistance. When the inclined angle is negative, the nose is in the lowest point of cutting edge. When the cutting edge enters the workpiece, the contacting point is on the cutting edge or rake face, protecting the nose from impact and increase the strength of the nose. Normally, negative inclined angle should be chosen for tools with big rake angle. This can not only increase nose strength. But also prevent the impact of entry.

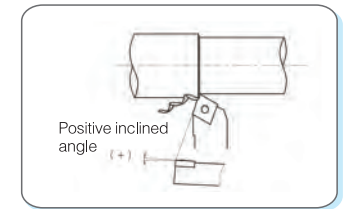

#### 5 Effects of Approach Angle

Reduces approaching angle increases the strength of tools and enable heat to diffuse easily, improving surface quality. This is because when the approach angle is small, cutting edge width is large, and then the unit width of cutting edge bears less cutting force. Meanwhile, tool life can be improved.

Normally, select 90° approach angle for turning of slender and step shaft; select 45° approach angle for external turning, End surface machining and chamfering. When approach angle is larger, radial force is reduced, cutting is stable, cutting thickness is increased, and chip breaking is excellent.

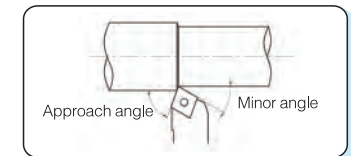

Value selection	Situations
Small approach	For those materials with high intensity, high hardness and hardened layer on the surface
Big approach angle	When rigidity of the machine is not enough

#### 6 Effects of Minor Angle

Minor angle is the main angle that can affect surface quality, and it can also affect tool strength. If the approach angle is too small, the friction between the secondary flank and machined surface of workpiece will increase, causing vibration. The principle of selecting minor angle: Select small minor angle when roughing or when the friction is unaffected and is on vibration. Select large minor angle when finishing.

#### 7 Effects of Cutting Edge Grinding

According to different use occasions, choose a cutting edge method from the table below

Shape of the cutting edge	shape
sharp edge	
comer	
chamfer	



Cutting edge grinding is a processing method used to maintain the cutting edge strength. The grinding amount is large, the cutting edge strength is high, not easy to damage, the tool life is improved, but the excessive grinding amount will cause the edge sharpness is not enough, the cutting force will be large, but also may produce vibration.

Value selection	Situations
Small regrinding amount	<ul style="list-style-type: none"> <li>• Finishing machining – small <math>A_p</math> &amp; <math>F_n</math></li> <li>• For processing soft materials</li> <li>• When the machine or workpiece is not rigid enough</li> </ul>
Large regrinding amount	<ul style="list-style-type: none"> <li>• Rough machining</li> <li>• When machining hard materials and intermittent cutting</li> <li>• When machine rigidity is good</li> </ul>

### 8 Nose Radius

Nose radius significantly affects nose strength and surface quality.

Large nose radius means higher cutting edge strength, and the abrasion on the rake face and clearance face can be reduced to some extent. However, if the nose radius is too large, radial force will increase, and vibration is easy to occur, affecting machining precision and surface quality

Value selection	Situations
Small nose radius	<ul style="list-style-type: none"> <li>• Finishing at small cutting depth</li> <li>• Machining parts such as slender shaft</li> <li>• When the rigidity of the machine is not enough</li> </ul>
Large nose radius	<ul style="list-style-type: none"> <li>• When roughing</li> <li>• When machining hard materials (intermittent cutting)</li> <li>• When the rigidity of the machine is good enough</li> </ul>

## Calculation Method of Turning Parameters

### 1 Calculation of Cutting Speed

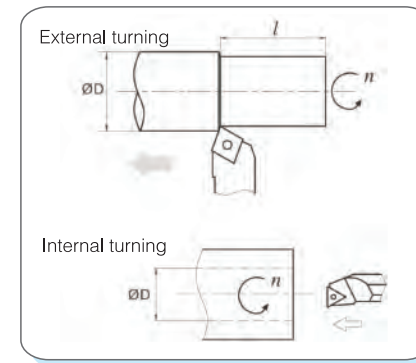

$$V_c = \frac{\pi \times D \times n}{1000} (m/min)$$

In the formula:

$V_c$ : Cutting speed(m/min)

$n$ : Rotating speed of main axle (rev/min)

$D$ : Diameter of workpiece(mm)

For example: When the rotating speed is 500ev/min and the diameter of workpiece is 80mm, the cutting

$$V_c = \frac{\pi \times D \times n}{1000} = \frac{3.14 \times 80 \times 500}{1000} = 125.6(m/min)$$

### 2 Calculation of Feed Rate

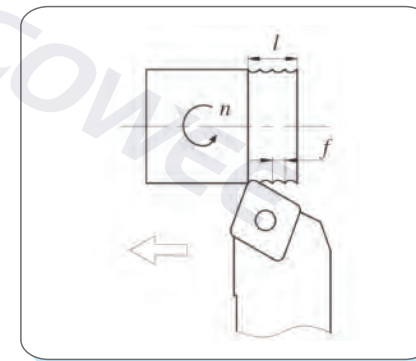

$$f = \frac{l}{n} (mm/rev)$$

In the formula:

$f$ : Feed rate per rotation(mm/rev)

$L$ : Cutting length per minute(mm/min)

$N$ : Rotating speed of main axle(rev/min)

For example: When the rotating speed of main axle is 600ev/min, and the cutting length per minute is 150mm/min, the feed rate per rotating should be:

$$f = \frac{l}{n} = \frac{150}{600} = 0.25(mm/rev)$$



3 Cutting Time Calculation of External and Internal Turning

$$T = \frac{l}{f \times n} \text{ (min)}$$

In the formula: T: Cutting time(min)  
 L: length of machined areas(mm)  
 F: Feed rate(mm/rev)  
 N: Rotating speed of main axle(rev/min) For example: When the rotating speed of main axle is 300rev/min, and the feed rate is 0.15mm/rev. the time needed for a cutting length of 180mm should be:

$$T = \frac{l}{f \times n} = \frac{180}{0.15 \times 300} = 4 \text{ min}$$

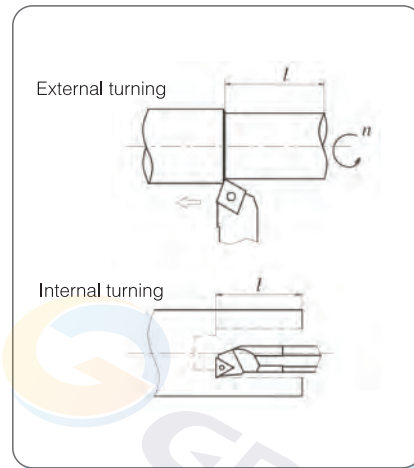

4 Time Calculation End Surface Turning (Constant Linear Speed)

$$T = \frac{\pi \times (a^2 - b^2)}{4000 \times V_c \times f} \text{ (min)}$$

In the formula: T: Cutting time(min)  
 Vc: length of machined areas(mm)  
 F: Cutting speed For end surface without hole, b = 0, the formula is still Valid.

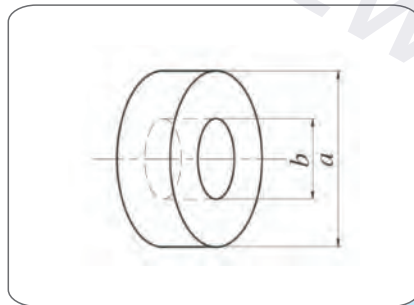

5 The Oretical Value Calculation of Machined Surface Roughness

$$R = \frac{f^2}{8r_c} \times 1000 (\mu\text{m})$$

In the formula: R: Theoretical roughness value of machined surface  
 F: Feed rate(mm/rev)  
 Rc: Nose radius(mm)  
 For example: When the feed rate is 0.25mm/rev, and the nose radius is 0.8mm. the theoretical roughness value of machined surface should be:

$$R = \frac{f^2}{8r_c} \times 1000 = \frac{0.25^2}{8 \times 0.8} \times 1000 = 9.76 (\mu\text{m})$$

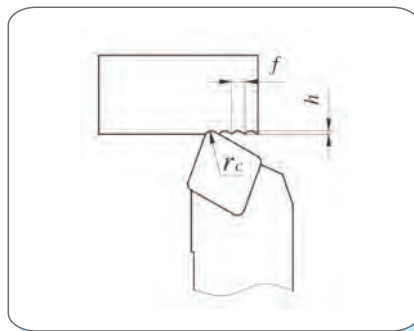

The Influence of Three Elements of Turning on Machining

Normally, short machining time, long tool life and high machining precision are expected in machining, so the material quality, hardness, and shape of the workpiece, and properties of machine should be fully considered and then we can select suitable tools and adopt high-efficiency cutting parameters, namely three parameters.

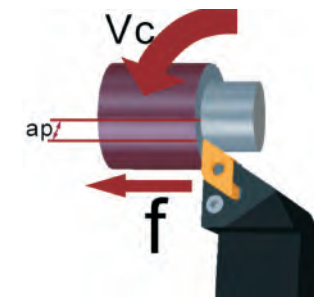

1 Cutting Speed (Vc)

(1) Definition of cutting speed  
 When the workpiece is rotating on the machine, the number of its rotation per minute is defined as Rotating speed of main axle (n). Because of its rotation, the cutting speed measured on the contacting point of diameter is defined as linear speed. (m/min). Normally, linear, linear speed is considered to measure the effect of cutting speed on machining.

(2) Effect of Cutting Speed  
 Cutting speed has significant effect in tool life. When the cutting speed is increased, cutting temperature will increase and tool life will be shortened. Cutting speed varies according to the different types and hardness of work-piece. The below conclusions are reached after many cutting experiments:

- Normally tool life would be reduced to half when the cutting speed is increased by 20%. Tool life would be 20% of the original life if the cutting speed is raised by 50%.
- Low speed (20-40m/min) cutting could easily cause vibration and shorten tool life.

2 Feed Rate (Fn)

(1) Definition of feed rate  
 Feed rate is defined as the moving distance of tool after workpiece rotates for one circle, measured by mm/rotation.

(2) The influence of feed rate  
 Feed rate is a key factor that determines surface quality. Meanwhile it also affect the range of chip forming and the thickness of chips during machining.

In term of the effect on tool life, small feed rate leads to serious abrasion on clearance face, reducing tool life.



## 3 Cutting Depth(ap)

### (1) Definition of cutting depth

Cutting depth is defined as the difference between machined surface and unmachined surface. Measured by mm. it is half the difference value between the original diameter and machined diameter.

### (2) Effect of Cutting Depth

Cutting depth should be determined by the machining allowance and shape of workpiece, power and rigidity of machine, and tool rigidity.

The change of cutting depth has little effect on tool life. If the cutting depth is too low. The cutting nose only scrapes the hardened layer on the workpiece surface, reducing tool life. When there is hardened oxide layer on workpiece surface, higher cutting depth should be adopted within the possible range of machine's power to avoid cutting nose just cutting the hardened layer of workpiece.

## Blade Wear and Solution

### (1) Flank Wear



**Problem:**  
Higher cutting resistance. Notch wear on flank. Poor roughness of surface or deterioration of accuracy

**Reason:**  
Soft grades. Excessive cutting speed. Small flank angle. Low feed

**Solutions:**  
Select a higher wear-resistant grade. Reduce cutting speed. Increase flank angle. Increase feed



### (2) Crater Wear



**Problem:**  
Uncontrolled chip. Poor surface quality when finishing. High speed processing carbon steel

**Reason:**  
Soft grades. Excessive cutting speed. Excessive feed. The strength of chip breaker. Insufficient

**Solutions:**  
Change to a higher wear-resistant grade. Reduce cutting speed. Reduce feed. Select a higher strength chip breaker

### (3) Plastic Deformation



**Problem:**  
Variation of dimension. Nose wear, cutting edge drupe or passivating, when processing alloy steel. Poor surface roughness

**Reason:**  
Soft grade. Excessive cutting speed. Excessive cutting depth and feed rate. Overheat on cutting edge

**Solutions:**  
Select a higher red hardness cutting material. Decrease cutting speed. Decrease cutting depth and feed rate. Select a higher thermal conductivity cutting material (CVD + sufficient coolant)

### (4) Build-Up-Edge



**Problem:**  
Workpiece dissolve with Cutting edge. Poor surface roughness when finishing. Cutting resistance increased. Cutting soft materials

**Reason:**  
Cutting speed too low. Cutting edge obtuse. Unsuitable tool material

**Solutions:**  
Increase cutting speed. Increase rake angle. Select small sticking force

### (5) Chip Hammering



**Problem:**  
Part of the cutting edge that does not participate in cutting is damaged by chip hammering, the upper and support of the insert may be damaged.

**Reason:**  
Chip folds back to the cutting edge

**Solutions:**  
Change the feed rate and choose another type of chip breaker

### (6) Insert Fracture



**Problem:**  
Cutting resistance increased. Poor surface Roughness

**Reason:**  
Toughness insufficient. Excessive feed rate. Strength of cutting edge insufficient. Instability of the tool

**Solutions:**  
Select a tougher grade. Decrease feed rate. Increase honing of cutting edge (chamfering to rounding). Increase the stability and setting angle

### (7) Thermal Crack



**Problem:**  
Crack by heat cycle (often happen in milling and interrupted cutting)

**Reason:**  
Toughness of tool grade insufficient. Swell and shrink by cutting heat (cold-thermocycling)

**Solutions:**  
Cutting without coolant/Sufficient coolant. Select a tougher and more thermal shock resistance grade

### (8) Chipping

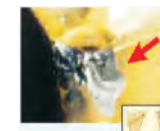

**Problem:**  
Sudden fracture of cutting edge (rake face and flank). Instability insert life

**Reason:**  
Toughness insufficient. Excessive feed rate. Strength of cutting edge insufficient. Instability of the tool

**Solutions:**  
Select a tougher grade. Decrease feed rate. Increase honing of cutting edge (chamfering to rounding). Increase the stability and setting angle



## Second Part: Technical Information About Indexable Milling Tools

### Function of Each Part in Face Milling

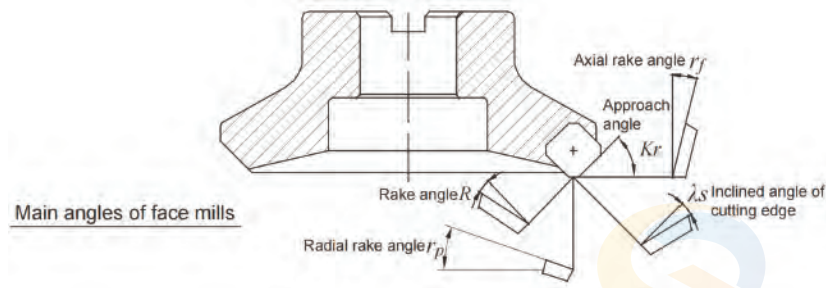

Designation	Function	Effect
Axial rake angle $\gamma_f$	Determining the chip direction	Negative, excellent capability of chip removal
Radial rake angle $\gamma_p$	Determining whether the cutting is easy and fast or not	Positive angle: good cutting performance
Approach angle $K_r$	Determining the chip thickness	$K_r \uparrow$ , chip thickness $\uparrow$ ; $K_r \downarrow$ chip thickness $\downarrow$
Rake angle $R_o$	Determining whether easy and fast the cutting is or not	Poor cutting performance, High - Poor cutting strength cutting edge (-) $\leftarrow 0 \rightarrow$ (+) Good cutting performance, Low strength cutting edge
Inclined angle $\lambda_s$	Determining the chip flow direction	Poor capability of chip removal, High - strength cutting edge (-) $\leftarrow 0 \rightarrow$ (+) Good performance of chip removal, Low - strength cutting edge

### 1 Milling Cutter Parameters Selection

• Characteristics of Different Rake Angles Combined

		Double positive rake angle	Double negative rake angle	Positive and negative rake angle
Negative rake angle				
0° rake angle				
Positive rake angle				
Axial rake angle $\gamma_f$		+	-	+
Radial rake angle $\gamma_p$		+	-	-

Applicable material machined	P	✓		✓
	M	✓		✓
	K		✓	✓
	N	✓		
	S	✓		✓

### 2 Selection of Approach Angle

• Selection Method of Cutting Tools

Designation	Schematic diagram	Instruction
45°		Axial force is the largest, it will bend when machining thin-wall workpiece, reducing the precision of workpiece. It can help avoid fringe breakage of workpiece when machining cast iron
75°		The main force is radial cutting force, in is often used in general face milling
90°		The main force is radial cutting force, in is often used in general face milling



### 3 Selection of Approach Angle :

The approach angle is formed by insert and tool body. It affects chip thickness. Cutting forces and tool-life. Decreasing the approach angle reduces chip thickness and expands the cutting area between cutting edge and workpiece at a given feed rate. A Smaller approach angle also ensures stable entry into or exiting workpiece, protecting the cutting edge and extending tool life. However, this will increase axial cutting forces on the workpiece, thus is not suitable for machining thin workpiece Such as thin plate.

Approach angle	Feed rate per tooth $f_z$	Maximum chip stickiness $h_{ex}$
90°	$f_z$	$h_{ex} = f_z \times \sin Kr$
75°	$f_z$	$h_{ex} = 0.96 \times f_z$
60°	$f_z$	$h_{ex} = 0.86 \times f_z$
45°	$f_z$	$h_{ex} = 0.707 \times f_z$
Circular Blade	$f_z$	$h_{ex} = \frac{\sqrt{ic^2 \times (ic - 2a_p)^2}}{ic} \times f_z$

### 4 Pitch Selection

Pitch is the distance between one point on one cutting edge and the same point on the next edge.

Optimized stability		
L ( Low )	M ( Medium )	H ( High )
<p>Coarse pitch</p>	<p>Close pitch</p>	<p>Extra close pitch</p>
<p>When the milling width is equal to diameter of cutter, the machining system is stable and main power of machine is sufficient, the use of coarse pitch can achieve high productive efficiency.</p>	<p>Used in general milling and multiple mixed productions.</p>	<p>When the milling width is less than diameter of cutter, cutting by maximum edges can achieve high productive efficiency.</p>

## Milling Calculation

### 1 General Formula

$V_c$ : cutting speed ( m/min ) $D_c$ : nominal diameter of milling tool ( mm ) $n$ : spindle speed ( rev/min ) $z_n$ : number of teeth $Q$ : metal removal rate (cm <sup>3</sup> /min)	$V_f$ : feed rate of worktable ( feed speed ) ( mm/min ) $f_z$ : feed rate per tooth ( mm/z ) $\pi$ : circumference ratio=3.14 $T_c$ : machining time ( min ) $f_n$ : feed rate per revolution ( mm/rev ) $L$ : Actual working distance ( mm )
<p>●Cutting speed</p> $V_c = \frac{\pi \times D_c \times n}{1000} \text{ ( m/min )}$	  
<p>●Spindle speed</p> $n = \frac{1000 \times V_c}{\pi \times D_c} \text{ ( rev/min )}$	
<p>●Feed rate of worktable(feed speed)</p> $V_f = f_z \times n \times z_n \text{ ( mm/min )}$	
<p>●Feed rate per tooth</p> $f_z = \frac{V_f}{n \times z_n} \text{ ( mm/z )}$	
<p>●Feed rate per revolution</p> $f_n = \frac{V_f}{n} \text{ ( mm/rev )}$	
<p>●Machining time</p> $T_c = \frac{L}{v_f} \text{ ( min )}$	
<p>●Metal removal rate</p> $Q = \frac{a_p \times a_e \times V_f}{1000} \text{ cm}^3 / \text{min}$	



## Difference and Selection Between Down Milling and Up Milling

Climb milling (also called down milling): the feed direction of workpiece is the same as that of the milling rotation at the connecting position.

Conventional milling (also called up milling): the feed direction of workpiece is opposite to that of the milling rotation at the connecting position.

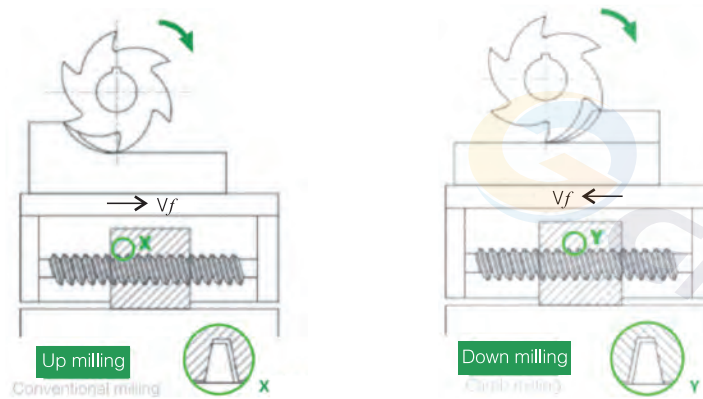

In down milling, the major force of cutting edge is the compressive stress, while in up milling is the tensile stress. The compressive strength of cemented carbide material is much larger than its tensile strength. In down milling, as chips become thin from thick gradually, cutting edge and workpiece press against each other. The friction between edge and workpiece is small, thus reducing the abrasion of edge, the hardening of workpiece surface and the surface roughness (Ra). In up milling, chips become thick from thin gradually. When the insert is cutting into the workpiece, it produces strong friction and more heat than in down milling, and make workpiece surface hardened.

In up milling, because horizontal direction of cutting force milling cutter conducting on workpiece is opposite to the feed direction of workpiece, the lead screw of worktable joints closely with one side of the screw nut. In down milling, the direction of cutting force is the same as the feed direction. When edge's radial force on workpiece is large enough, the worktable will bounce left and right, thus make the gap fall behind. The gap will return to the front side with the continuing rotation of lead screw. At this moment the worktable stops motion, however, it will bounce left and right again when the radial cutting force is large enough again. The periodical bounce of worktable will cause poor surface quality of workpiece and tool breakage.

When using end mills for down milling, the edges always starts cutting at the workpiece surface, therefore end mills are not suitable for machining workpiece with hardened surface

Up milling is recommended for milling thin-wall components or square milling with high requirement for precision.

## CVD Grades Comparison Table

ISO	WeCoTool	SANDVIK	KENNAMETAL	SecoTool	ISCAR	TaeguTec	Walter	TUNGALOY	KYOCERA	KORLOY	SUMITOMO	MITSUBISHI	ZCC.CT
P10	GW2134	GC4315	KCP10 KC9110	TP1500	IC5005 IC8150	TT8115	WPP05S WPP10S	T9115	CA5505 CA5515	NC3215	AC810P AC820P	UE6110 MY5015	YBC151 YBC152
P20	GW2234	GC4325	KCP25 KC9125 KC9225	TP2500	IC8150 IC8250	TT5100 TT8125	WKP25S WPP20S WMP20S	T9025 T9125	CA5515 CA5525	NC3225 NC3120 NC5330	AC2000 AC820P	UE6020 MC6025 F7030	YBC251 YBC252
P30	GW2354	GC4325 GC4335	KCP30 KCP40	TP3000	IC8250 IC8350	TT8125 TT5100	WKP35S WPP30S WMP20S	T9135 T9035	CA5525 CA5535	NC3030 NC5340 NC500H	AC630M AC830P	UE6020U E6035U H6400	YBC252 YBC351
M10		GC2015	KCM15		IC6015 IC8150	TT9215	WMP20S		CA6515 CA6015	NC9115	AC610M AC630M	US7020 MC7015	YBM251 YBM153
M20		GC2015 GC2025	KCM15 KC9225	TM2000	IC6025 IC8150 IC8250	TT9225	WMP20S	T6020 T6130	CA6515 CA6525	NC9115 NC9125 NC5330	AC630M AC830P	US7020 MC7015 MC7025	YBM251 YBM253
M30		GC2035 GC2025	KCM25 KC9230	TM4000	IC6025 IC8250 IC8350	TT5100	WSM45X	T6130	CA6525	NC5340 NC5350 NC9135	AC630M	MC7025 US735 F7030	YBM351
K10		GC3210 GC3215	KCK05 KCK15	TK1000	IC5005 IC5010	TT1300	WAK15 WPP01	T5010 T5115	CA4505 CA4010	NC6315	AC410K	UC5115 MY5015	YBD102 YBD152
K20	GW1153	GC3215	KCK15 KCK20	TK2000	IC5005 IC5010	TT7105 TT7310	WKP25S WPP10S	T5115 T5125	CA4515 CA4115	NC6315 NC5330	AC410K AC420K	UC5115 UE6110 MC5020	YBD152
K30	GW0403	GC3225	KC9325		IC5010		WKP35S WPP20S	T5125		NC5340	AC820P	UE6110	YBD252

# PVD Grades Comparison Table

ISO	WeCoTool	SANDVIK	KENNAMETAL	SecoTool	ISCAR	TaeguTec	Walter	TUNGALOY	KYOCERA	KORLOY	SUMITOMO	MITSUBISHI	ZCC.CT
<b>P10</b>	GW0251	GC1010 GC1025	KC715M		IC807 IC907	TT7030 TT7080	WXM15 WSM10 WSM10S		PR730 PR830 PR1225		ACP100 ACP200	VP10MF	YBG102 YBG105
<b>P20</b>	GW8251 GW5251 GW0251	GC1010 GC1025 GC2030	KC522M KC525M	CP200	IC807 IC907 IC3028	TT7030 TT9030 TT9080	WSM20 WSM20S WSM21	AH725 AH120 GH330	PR730 PR830 PR1225	PC3600	ACP200	VP15TF VP20RT VP20MF	YBG202 YBG205
<b>P30</b>	GW0251	GC1025 GC1030	KC725M KC530M	CP500	IC807 IC808 IC3028	TT8080 TT9030 TT9080	WSP45S WSP46 WSM30S	AH730 GH130 AH130	PR660 PR1230	PC3600 PC3500 PC5300	ACZ300 ACZ350 ACZ200	VP15TF VP30RT VP20MF	YBG302
<b>M10</b>	GW8241	GC1025 GC1030	KC715M	CP200	IC807		WSM10 WSM10S		PR630 PR730 PR1225	PC8105 PC8110	ACP200	VP10MF	YBG202 YBG205
<b>M20</b>	GW8241 GW5251 GW8281	GC1025 GC1030	KC5025 KC715M	CP200 TS2500 CP500	IC354 IC807 IC3028	TT9030 TT9080	WSM20 WSM20S WSM21	GH120 AH120 AH725	PR660 PR730 PR1225	PC8110 PC8115 PC5300	ACZ310 AC520U ACP300	VP15TF VP20RT VP20MF	YBG202 YBG205 YB9320
<b>M30</b>	GW8281	GC1030 GC1040 GC2030	KC725M KC5525	CP500 F30M	IC808 IC908	TT8080 TT9030 TT9080	WSP35S WSP36 WSM30S	AH130 GH130 AH730	PR660 PR730	PC5300 PC9530 PC5400	ACZ330 AC520U ACZ350	VP15TF VP30RT MP7030	YBG302 YBG402
<b>K10</b>	GW0151	GC1210	KC5010 KC510M	CP200	IC910		WHH15 WXM15	AH110 GH110	PR510 PR905 PR1210	PC8110 PC6510	ACZ310 ACK200	VP10RT	YBG102 YBG105
<b>K20</b>	GW8251 GW5251 GW0251	GC1020 GC1220	KC5025 KC520M KC525M	CP200 CP500	IC808 IC908	TT6080	WKK25S	AH120 GH110 AH330	PR905 PR1210	PC5300	ACZ310 ACK200	VP15TF VP20RT	YBG202
<b>K30</b>	GW0251	GC1020	KC735M KU25T	CP500	IC808 IC908		WKK25S	GH130		PC5400	ACZ330 ACK300	VP15TF VP20RT	YBG205 YBG302
<b>S10</b>	GW6051 GWR6101	GC1025	KC510M KC5510 KCS10B	CP200 TS2000	IC806	TT9030	WSM10 WSM10S	AH905 AH110 SH730	PR660 PR905	PC8105 PC8110	EH520Z EH20Z AC510U	VP10RT VP20RT	YBS103
<b>S20</b>	GW5251 GWR5201 GWR5251	GC1025 GC2030	KC522M KC525M KC5525	CP250 TS2500 CP500	IC806 IC807 IC808	TT9030 TT9080	WSM20 WSM20S WSM21	AH120 AH725	PR1225 PR905	PC8115 PC5300	EH520Z EH20Z AC520U	VP15TF VP20RT MP9130	YBS203
<b>S30</b>	GWR0291 GWR0301	GC2030 S30T	KC725M	F40M	IC8350	TT8080 TT9030 TT9080	WSM45S WSP46 WSM30S	AH725	PR905	PC5400	ACK300 AC520U	VP15TF	YBS303

